



TABLET COMPRESSION
ACCESSORIES CATALOG
SEVENTH EDITION

WELCOME

Welcome to the only comprehensive tablet compression accessories catalog in the industry. We've packed this catalog with hundreds of carefully selected products (many of them exclusive) that will help you improve tooling life, tablet quality, and overall efficiency.



World Headquarters &
Tool Manufacturing Facility
St. Charles, Missouri, USA



STEEL PREPARATION FACILITY
St. Charles, Missouri, USA



TECHNICAL TRAINING & PRESS REFURBISHING FACILITY
St. Charles, Missouri, USA



TURRET MANUFACTURING FACILITY
Chesterfield, Missouri, USA



PARTS & ACCESSORIES DISTRIBUTION CENTER
Chesterfield, Missouri, USA

WHO WE ARE



When Carmelo Natoli established Natoli Engineering in 1973, his philosophy was simple:

Deliver a quality tool at a fair price with exceptional customer service.

That philosophy, along with our commitment to innovation, has made Natoli Engineering the undisputed leader in the tablet compression tooling industry.

We are committed to developing groundbreaking solutions through research and development of steel types, punch coatings, and tooling design. We also develop solutions for tooling and tablet analysis, storage, and more.

TOOLING

Our tablet compression punches and dies are manufactured from the highest quality steel for optimum strength and durability, a hallmark of Natoli Engineering.

Our quality tooling is made from the best steel that is quarantined and tested to our stringent standards and then passed through a computerized vacuum internal quench heat-treating system—guaranteeing batch-to-batch consistency.

We offer multiple custom tool configurations and design options to meet your needs and specifications. We can design your tool to meet the stringent requirements of your product to ensure tablet quality and enhance production.



TABLET PRESSES & REFURBISHING

Natoli Engineering's tablet presses provide superior performance. Our line of reliable tablet presses range from tablet presses for research and development to high-output, automated production presses.

We offer refurbishing services for most makes and models of tablet presses. Our experts customize and rebuild each press to exceed the quality and functionality of the original. The AIM™ operating system can be retrofitted to your press to increase production and improve tablet consistency.

TABLET PRESS REPLACEMENT PARTS

Natoli Engineering maintains a comprehensive inventory of tablet press replacement parts ready for immediate delivery. Our premium parts are available for most press makes and models and meet or exceed OEM specifications. Ask your Natoli sales representative for a copy of our Tablet Press Replacement Parts catalog or visit natoli.com.

ENCAPSULATION

Natoli Engineering, through its Carlisle Precision Encapsulation Parts subsidiary, manufactures premium change and spare parts for many brands of encapsulation machines. Precision engineered and manufactured from the highest quality materials, Natoli encapsulation change and spare parts meet and often exceed the functionality and longevity of OEM parts. All parts are manufactured by Natoli in the USA. Ask your Natoli sales representative for a copy of our Encapsulation Replacement Parts catalog or visit natoli.com.



TECHNICAL TRAINING at NATOLI ENGINEERING

Natoli's experienced instructors provide technical training at our St. Charles, Missouri, headquarters, at regional Natoli service centers, and on-site for customers around the world. Join our team at one of our tablet compression or encapsulation courses for an immersive classroom and hands-on experience.

Natoli Engineering's training will keep you engaged and learning. Each training event at our state-of-the-art facilities features open discussions, one-on-one consultations, Q&A, and live demonstrations.

Attendees at our tablet manufacturing and troubleshooting classes gain an in-depth understanding of tablet shapes and designs, tablet press setup and operation, tooling options, steel types, tooling inspection, and tooling reworking and polishing. Our encapsulation courses help attendees learn solu-



tions to common encapsulation challenges and give hands-on experience with proper segment and dosing disk alignment.

We look forward to welcoming you to our facilities in St. Charles, Missouri; Long Island, New York; Southern California; and Szczecin, Poland.

NATOLI SCIENTIFIC

Natoli Scientific was founded to research new formulation techniques and tablet compression technology. It combines four decades of experience with a network of university, consultant, and resident resources to offer customers solutions to their tablet and capsule research and development, scale-up, and manufacturing challenges. Natoli Scientific provides:

- Tablet and capsule troubleshooting and formulation evaluation
- Contract research and development services
- Training focused on research and development processes
- Calibration services and documentation for instrumented tablet presses
- Instrumentation system retrofit for tablet presses, roller compactors, high-shear granulators, and encapsulators



Natoli Institute for Industrial Pharmacy Research and Development

Natoli Scientific has facilities in St. Charles, Missouri, and Telford, Pennsylvania. In addition, Natoli Scientific established the Natoli Institute for Industrial Pharmacy Research and Development with the Arnold and Marie Schwartz College of Pharmacy and Health Sciences at Long Island University (LIU) to offer formulation assessments and research new formulation techniques and technologies.

WHO SHOULD ATTEND?

Technical courses are designed for anyone wanting to learn more about tablet compression or encapsulation. The courses benefit tooling technicians, tablet press operators, tablet press maintenance technicians, encapsulation machine operators and technicians, QC/QA personnel, R&D personnel, and their supervisors. Attendees receive valuable hands-on experience that cannot be learned from textbooks or webinars.



CUSTOM TRAINING CLASSES

In addition to our regularly scheduled training courses, we also offer customized courses tailored to your needs to help you accomplish your training goals. We will develop a training course that meets your needs to enrich skills, increase productivity, and enhance product quality.

Contact our training and events coordinator to discuss custom-training opportunities with Natoli Engineering at **636-926-8900**. To learn more and view upcoming training dates, go to: natoli.com/training.

Natoli Engineering's experts have written a three-volume set of white papers that cover subjects ranging from proper maintenance of tablet compression tooling to developing new formulations to troubleshooting tableting challenges. Visit www.natoli.com to download our white papers.

NATOLI SCIENTIFIC'S R&D LABORATORY

Natoli Scientific's laboratory facility in Telford, Pennsylvania, enables our researchers to evaluate and characterize the mechanical properties of formulations using a full range of lab-scale R&D and production tablet presses, dry and wet granulation machines, a compaction emulator, and coating equipment. Our contract research services can address each element of product development and help prepare you to meet GMP standards when your formulation goes into production.

Our tablet development contract services include:

- Formulation evaluation for sticking and picking problems
- Formulation evaluation for tool steel and coating recommendations
- Formulation modification to improve tableting and performance in the tablet press
- Investigation of tool steel failure

The facility also offers classroom and hands-on tablet manufacturing process training. Natoli Scientific classes help those involved with research and development learn about granulation principles and best practices; common excipients and their designed functions; the factors that can influence successful tablet coating; and the importance of characterization, measurement, blending, and more.

Our experienced staff can help resolve your questions at one of our laboratory facilities or at the Natoli Institute for Industrial Pharmacy Research and Development. Please contact Natoli Scientific at **636-926-8900** or visit natoli.com/natoli-scientific.

NATOLI ENGINEERING SERVICE CENTERS

Natoli Engineering's service centers, located in St. Charles, Missouri; Long Island, New York; Southern California; and Szczecin, Poland, offer regional customer support with parts, accessories, tool refurbishing, maintenance, training, and more.

Our experienced technicians are available for hands-on technical training, tooling inspection and maintenance, and tablet press repair. We can support your team in creating custom work instructions and offer consulting services to help establish critical step-by-step processes.

Stop by a Natoli service center to see the equipment in our showroom, or call us for same-day delivery of many tablet press parts and accessory products.



CYPRESS CALIFORNIA



LONG ISLAND NEW YORK

TABLETCAD® TABLET DESIGN SOFTWARE

TabletCAD® is the only program that lets you design tablets in-house, to your specifications, quickly, easily, and at NO COST.

Proper design is a key factor in tablet quality. That's why tablet design should not be overlooked or taken for granted.

Much too often in our industry, we see poor tablet design holding back companies. Don't let this happen to you! A well-designed tablet can:

- Ensure solid tablet quality
- Maximize tablet production
- Enhance the product lifecycle
- Create easy recognition, which builds brand equity and incorporates brand authentication

If you are developing a product, our engineers can help you create an efficient and effective tablet design based on best practices and your manufacturing requirements and restrictions.

TabletCAD® allows work to be done from any location, on any device (PC, tablet, and/or phone), and any operating system (Windows, Mac, iOS, Android).

With Natoli Engineering's TabletCAD®, it's as easy as 1...2...3!



WHAT WE PROVIDE

Whether you need training, troubleshooting, or a specific product or service, we can help with:

- Local inventory with same-day delivery on many parts and accessories
- Tablet compression tooling reworking, including inspection and validation
- Tablet compression and encapsulation training
- Tablet press assessment and repairs
- Tooling inspection and maintenance
- Troubleshooting and consulting



SZCZECIN POLAND

PREFERRED PARTS PROGRAM

Our Preferred Parts Program (PPP) guarantees that consumable replacement parts will always be on hand at special discounted prices and ready for expedient delivery.

- Earn discounts on commonly used parts
- Most essential wear items in stock locally
- No minimum purchase required
- No contract or long-term commitment
- Catalog items (oils, dust cups, etc.) also available

To learn more information about Natoli service centers, contact:
info@tabletcompressionresource.com

KEY FEATURES & BENEFITS

With TabletCAD®, your tablet designs are linked directly to the manufacturing process, so tooling will be shaped precisely to your models. An intuitive user interface guides you through the design process with helpful tips and real-time design validation.

Key features and benefits of TabletCAD® include:

- Smart design to guide you through the creation of your tablet
- Real-time surface area, volume, and perimeter calculations
- Simple user interface with tooltip information and links between dimensions and their controls
- Addition of common bisects such as standard, cut flush, and cut through to tablet design
- Real-time geometry validation
- Quick determination of tablet thickness specifications required for packaging
- Online help documentations and walkthroughs

TABLET **CAD**®
NATOLI ENGINEERING COMPANY



For **FREE** access to TabletCAD® tablet design tool visit natoli.com/tabletcad.

TABLE OF CONTENTS

Throughout the catalog, you'll see **"MUST HAVE"** products.

Natoli recommends these products for our customers to maintain tablet quality and increase the longevity of their tooling. From maintenance to compression to the lab, these products will improve efficiency and reduce cost in your operation. In some cases, items are made upon order and lead times may vary.



9

SET-UP

27

COMPRESSION SUPPORT EQUIPMENT

33

QUALITY ASSURANCE

39

CLEANING

49

INSPECTION

71

POLISHING

81

LUBRICATION

87

STORAGE SOLUTIONS

99

INDEX & REFERENCE

SET-UP

Proper tablet press set-up can maximize tool life and produce consistent, robust tablets. If presses are incorrectly set up, tablet defects like capping and weight variations, as well as severe damage to tooling, turrets, and other parts of the press can occur. **Natoli's Press Set-Up Toolboxes** contain everything needed to set up a tablet press correctly and eliminate unwanted downtime, unsafe working conditions, and thousands of dollars in repair costs. See page 10 for press make and models.



SET-UP

PRESS SET-UP TOOLBOXES

Our heavy-duty Press Set-Up Toolboxes contain everything needed to properly set up a tablet press. Each toolbox comes customized with the necessary tools and accessories for your specific press model.

- Order by machine type and number of stations
- Available for special or modified tablet presses
- All items can be purchased individually

TOOLBOXES INCLUDE:

- A. Protective storage case
- B. 6" (152.4 mm) feeler gauge
- C. 12" (308.4 mm) feeler gauge
- D. Punch guide cleaning brushes (2)
- E. Die pocket side-action brushes (2)
- F. Adjustable torque screwdriver
- G. Preset torque wrench
- H. Die insertion ring
- I. Die seat cleaner tool
- J. Hex socket adapter
- K. Die lock T-handle
- L. Precision straight edge
- M. Die driving rod with two replacement tips
- N. Tight punch removal tool
- O. Dial indicator with magnetic base for checking die table run-out
- P. Punch guide seal installation tool*



MUST HAVE!

Part No.	Press Set-Up Toolbox Suitable for
SU 0240	Cadmach "BB"
SU 0241	Cadmach "D"
SU 0256	Courtoy "D" or Piccola 8-Station
SU 0257	CPT Stealth 30-Station or Sejong "D"
SU 0242	Fette "B"
SU 0243	Fette "BB"
SU 0244	Fette "D"
SU 0245	Kikusui "B"
SU 0258	Kikusui "BB"
SU 0273	Kikusui "D"
SU 0246	Korsch "B"
SU 0408	Korsch "BB"
SU 0272	Korsch "D"
SU 0270	Kilian "B"
SU 0271	Kilian "D"
SU 0274	Kilian "BB"
SU 0247	Bosch Manesty "B"
SU 0248	Bosch Manesty "BB"
SU 0249	Bosch Manesty "D"
SU 0250	Natoli NP-100 (27 or 35 Station) or Stokes "B"
SU 0251	Natoli NP-100 (45 Station) or Stokes "BB"
SU 0278	Natoli NP-155 (35 or 37 Station) "B"

Part No.	Press Set-Up Toolbox Suitable for
SU 0279	Natoli NP-155 (45 Station) "BB"
SU 0252	Natoli NP-250 (16 or 20 Station) or Stokes "D"
SU 0263	Natoli NP-250 (15 Station) or Stokes DS3-15
SU 0405	Natoli NP-255 (22 Station) "D"
SU 0406	Natoli NP-255 (16 Station) "D"
SU 0407	Natoli NP-255 (28 Station) "B"
SU 0275	Natoli NP-400 (22 Station) "D"
SU 0276	Natoli NP-400 (28 Station) "B"
SU 0277	Natoli NP-400 (32 Station) "BB"
SU 0266	Natoli NP-500 (45 Station)
SU 0267	Natoli NP-RD10
SU 0315	Natoli NP-RD10A
SU 0316	Natoli NP-P20 or NP-RD20
SU 0254	Piccola "D"
SU 0255	Piccola "B" or Sejong "B"
SU 0253	Stokes "Premier"
SU 0262	Stokes 533/328-45
SU 0264	Stokes DD2 (31 Station)
SU 0268	Stokes DD2-23 or DDS2-23
SU 0265	Stokes 533/328-33
SU 0141	Special Order Press Set-Up Toolbox

*Manesty Presses Only (not pictured—see page 18).

EASY-TO-USE OVERLOAD AND STRAIN GAUGE CALIBRATION KIT

Use to accurately confirm machine calibration overload and strain gauge systems. **Periodically confirming gauge values will reduce potential press and tool damage.**

- NIST certified (Certificate of Calibration available upon request)
- Load cell verifies that tonnage gauge values are accurate
- Kit includes protective storage case
- Calibration punches must be ordered separately

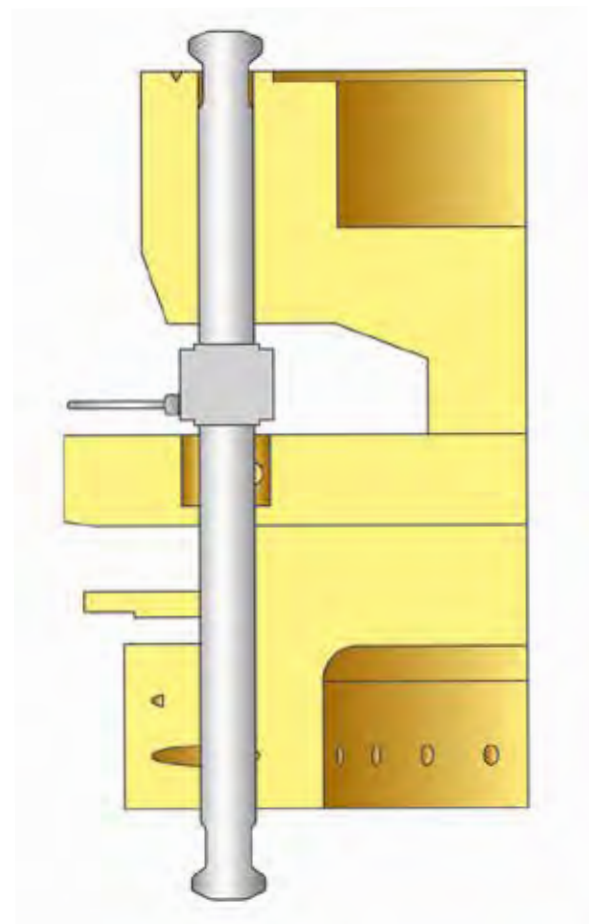

Part No.	Item Description
IN 7759	Overload and Strain Gauge Calibration Kit
IN 7762	"B" Lower Overload Calibration Punches
IN 7763	"B" Upper Overload Calibration Punches
IN 7764	"D" Lower Overload Calibration Punches
IN 7765	"D" Upper Overload Calibration Punches
IN 7768	EU "B" Lower Overload Calibration Punches
IN 7769	EU "B" Upper Overload Calibration Punches
IN 7775	EU "D" Lower Overload Calibration Punches
IN 7774	EU "D" Upper Overload Calibration Punches
IN 7772	"B2" Short Lower Overload Calibration Punches
IN 7780	Special Order Overload Calibration Punches
IN 7760	Replacement Load Cell Indicator—NIST Certified
IN 7761	Replacement Load Cell (0–10 tons)—NIST Certified
SU 0146	Replacement Storage Case with Foam Insert

ROTATING HEAD MAINTENANCE KIT

Use to accurately disassemble and reassemble rotating punch heads for cleaning, lubrication and inspection.

KIT INCLUDES:

- 5" (127 mm) V-block and clamp
- Punch body securing block
- Pin driver (for 5/32" dia. slotted spring pins)
- Bag of 100 slotted spring pins
- Head alignment gauge
- Die countercheck
- **How to Disassemble and Assemble a Rotating Punch Head DVD**
- Protective storage case



ROTATING HEAD MAINTENANCE KIT	
Part No.	Item Description
IN 8010	"B" Rotating Head Maintenance Kit
IN 8011	"D" Rotating Head Maintenance Kit
IN 8012	533/328 Rotating Head Maintenance Kit
SU 2531	Natoli Moly Supreme NLGI #2 Grease (14 oz.)

MULTI-TIP MAINTENANCE KIT

Easily disassemble and reassemble assembly-type multi-tip punches for proper maintenance. Customization available, pending your specific tool requirements.

KIT INCLUDES:

- 5" (127 mm) V-block and clamp
- Punch body securing block
- Alignment gauge
- Pin drivers (for 3 mm dia. coiled spring pins) for installation and removal
- **Multi-Tip Punch Assembly DVD**
- Protective storage case



MULTI-TIP MAINTENANCE KIT	
Part No.	Item Description
MA 1110	"BB" Multi-Tip Maintenance Kit
MA 1111	"B" Multi-Tip Maintenance Kit
MA 1112	"D" Multi-Tip Maintenance Kit
MA 1001	Replacement "BB" Alignment Gauge (#1 Die)
MA 1002	Replacement "B" Alignment Gauge (#2 Die)
MA 1003	Replacement "D" Alignment Gauge
MA 1004	Replacement 100 "B" Coiled Spring Pins
MA 1005	Replacement 100 "D" Coiled Spring Pins
MA 1009	Steel Hammer Accessory

CUSTOMIZABLE ROTATING HEAD AND MULTI-TIP KITS AVAILABLE UPON REQUEST.

PRESET TORQUE WRENCHES

Improperly torqued dies can crack, split, or "pop up," resulting in damage to the feed frame and tooling causing thousands of dollars in repair costs. Using preset torque wrenches ensures dies are torqued to the exact specifications listed in the tablet press manual. **Special orders available.**

L-HANDLE TORQUE WRENCHES 1/2" DRIVE WITH "CLICK" DESIGN

Click-type wrenches are a must to achieve specified torque. A distinct "click" is felt and heard when proper torque is reached.

- Mandatory for tightening all types of die lock screws
- Recalibrate in-house with a torque analyzer (see page 14)



L-HANDLE TORQUE WRENCHES 1/2" DRIVE			
Part No.	Ft.-lb.	Nm.	Handle Color
SU 0162	7.38	10	Light Green
SU 0001	10	13.56	Light Blue
SU 0158	11.06	15	Maroon
SU 0002	12	16.27	White
SU 0023	13	17.63	Dark Green
SU 0003	14	18.98	Orange
SU 0004	15	20.34	Red
SU 0005	20	27.11	Yellow
SU 0006	25	33.90	Black
SU 0007	30	40.67	Blue

T-HANDLE TORQUE WRENCHES 3/8" DRIVE

Critical for properly torquing upper punch key screws and multi-tip tooling assemblies.



T-HANDLE TORQUE WRENCHES 3/8" DRIVE		
Part No.	Ft.-lb.	Nm.
SU 0186	7.38	10
SU 0175	10	13.56
SU 0187	11.06	15
SU 0177	12	16.27
SU 0176	13	17.63
SU 0178	14	18.98
SU 0179	15	20.34
SU 0181	20	27.11

T-HANDLE TORQUE WRENCHES 1/4" DRIVE

Critical for properly torquing upper punch key screws and multi-tip tooling assemblies.



T-HANDLE TORQUE WRENCHES 1/4" DRIVE			
Part No.	In.-lb.	Nm.	For Use With
SU 0200	8.9	1.0	Silver* M3 Punch Key Screws
SU 0201	16.5	13.56	Silver* M4 Punch Key Screws or Black** M3 Punch Key Screws
SU 0202	37.4	4.22	Black** M4 Multi-Tip Cap Assembly

*Silver screws are made of stainless steel.
**Black screws are made of carbon steel.

FOR PROPER CALIBRATION, A TORQUE WRENCH ANALYZER MUST BE USED (SEE PAGE 14).

VERITORQ® DIGITAL TORQUE ANALYZERS

The VeriTorg® analyzer quickly verifies proper torque settings for click-type and cam-over torque wrenches and screwdrivers. Proper torque settings prevent potential press and tooling damage and reduce downtime.

FEATURES:

- Meets or exceeds ASME B 107.24M and ISO 6789
 - » ±1% indicated value accuracy from 10–100% of capacity
 - » For horizontal or vertical surfaces

VERITORQ® DIGITAL TORQUE ANALYZERS

Part No.	Item Description
MA 5161	VeriTorg® Digital Torque Analyzer (50 in-lb.)
MA 5160	VeriTorg® Digital Torque Analyzer (80 ft-lb.)
MA 5162	VeriTorg® Digital Torque Analyzer (100 in-lb.)
MA 5163	VeriTorg® Digital Torque Analyzer (150 ft-lb.)



ADJUSTABLE TORQUE SCREWDRIVER WITH "CLICK" DESIGN

A distinct “click” is felt and heard when proper torque is reached. Recommended for torquing lower punch retainer screws and includes ¼" hex and bit.

- Meets ASME B 107.14M and ISO 6789 specifications in CW and CCW directions for:
 - » ±6% present value accuracy from 20–100% of capacity
 - » ±1.2% accuracy when set below 20% of capacity
 - » Calibration needed

ADJUSTABLE TORQUE SCREWDRIVER

Part No.	Item Description	Range
SU 0010	Adjustable Torque Screwdriver	7-36 in-lb.



ERGONOMIC PRESET TORQUE SCREWDRIVER

Recommended for torquing lower punch retainer screws.

- Quick-release bit holder for insert and power bits
- ¼" bits DIN 3126-C 6, 3 and E 6, 3
- ±6% EN ISO 6789 accuracy



ERGONOMIC PRESET TORQUE SCREWDRIVERS

Part No.	Item Description	Range
SU 0090	Preset Torque Screwdriver	2.5–11.5 in-lb.

DIE LOCK T-HANDLE WRENCHES

Use to install die locks prior to torquing or die lock removal.



DIE LOCK T-HANDLE WRENCHES

Part No.	Hex Size
SU 0070	5/16"
SU 0071	¼"
SU 0072	3/8"
SU 0073	7 mm
SU 0074	10 mm
SU 0076	8 mm

DIE LOCK HEX ADAPTERS

- ¼" drive for use with torque screwdriver or Manesty lower punch retainer screws (see page 13)
- 3/8" drive for use with T-handle torque wrench (see page 13)
- ½" drive for use with L-handle torque wrench (see page 13)
- Special order available

DIE LOCK HEX ADAPTERS

Part No.	Item Description	Drive Size	Adapter Size
SU 0008	Die Lock Hex Adapter	½"	5/16"
SU 0009	Die Lock Hex Adapter	½"	3/8"
SU 0015	Die Lock Hex Adapter	3/8"	5/16"
SU 0057	Die Lock Hex Adapter	3/8"	7 mm
SU 0059	Die Lock Hex Adapter	½"	7 mm
SU 0040	Die Lock Hex Adapter	½"	8 mm
SU 0065	Die Lock Hex Adapter	½"	10 mm



PRECISION FEELER GAUGES

Reduce product loss by accurately setting feeders with precision feeler gauges.

- Each leaf marked with a decimal range of 0.0015–0.025" and a metric range of 0.038–0.610 mm
- Constructed of hardened and tempered steel



PRECISION FEELER GAUGES

Part No.	Size
SU 0170	6" (152.4 mm)
SU 0156	12" (304.8 mm)



DIE DRIVING RODS WITH REPLACEABLE COMPOSITE TIPS

Prevent damage to dies and die pockets by using stainless steel Natoli Die Driving Rods with replaceable composite tips. **Throw away your brass and steel die driving rods. They may cause press and/or product contamination.**

- **Mandatory for use with carbide and ceramic-lined dies**
- Replacement tips can be purchased individually
- Custom sizes available upon request



DIE DRIVING RODS WITH REPLACEABLE COMPOSITE TIPS

Part No.	Barrel Diameter	Punch Type	Replacement Tips
SU 0011	0.75" (19.05 mm)	B	SU 0017
SU 0012	1.0" (25.4 mm)	D	SU 0018
SU 0013*	1.125" (25.58 mm)	533/328-45	SU 0019
SU 0014	1.25" (31.75 mm)	DS3	SU 0020
SU 0021	0.983" (24.97 mm)	Special	SU 0018
SU 0311	0.75" (19.05 mm)	8" (203.2 mm)	SU 0017
SU 0312	1.0" (25.4 mm)	8" (203.2 mm)	SU 0018
SU 0314	1.0" (25.4 mm)	5" (127 mm)	SU 0018

*Not available in stainless steel.

DIE INSERTION RINGS

Reduces die pocket damage by eliminating shaving of the die pocket wall during die set-up.

- Speeds set-up time with faster die insertion
- Ensures vertical alignment every time

DIE INSERTION RINGS

Part No.	Punch Type	Inside Diameter	Height
SU 0025	BB	0.945" (24 mm)	0.775" (19.68 mm)
SU 0027	B	1.1875" (30.1 mm)	0.775" (19.68 mm)
SU 0031	D	1.50" (38.1 mm)	0.837" (21.25 mm)
SU 0029	533/328-45	1.312" (33.32 mm)	1.25" (31.75 mm)
SU 0030	Kilian 25/32	1.3786" (35 mm)	0.892" (22.65 mm)
SU 0033	DD2-31	1.50" (38.1 mm)	1.25" (31.75 mm)
SU 0035	533/328-33	1.62" (41.14 mm)	1.25" (31.75 mm)
SU 0037	DS3	2.0" (50.8 mm)	1.125" (28.57 mm)
SU 0038	DD2 or DDS2	2.125" (53.975 mm)	1.375" (34.92 mm)
SU 0039	EU-BBS Fette	0.8666" (22.01 mm)	0.775" (19.68 mm)
SU 0046	BBS Korsch/Kilian	0.8268" (21 mm)	0.875" (22.22 mm)
SU 0032	Kilian Rx43	1.3791" (35.02 mm)	0.884" (22.45 mm)
SU 0063	Kilian 20/28	1.1820" (30.02)	0.884" (22.45 mm)



DIE SEAT CLEANER TOOLS

Cleans hard-to-reach die pocket corners.

- Essential for properly seating dies



DIE SEAT CLEANER TOOLS

Part No.	Punch Type	Diameter	Depth
SU 0041	BB	0.945" (24 mm)	0.875" (22.22 mm)
SU 0042	EU-BBS	0.8268" (21 mm)	0.875" (22.22 mm)
SU 0043	B	1.1875" (30.16 mm)	0.875" (22.22 mm)
SU 0044	BBS	0.8661" (22 mm)	0.875" (22.22 mm)
SU 0047	D	1.50" (38.1 mm)	0.937" (23.8 mm)
SU 0045	533/328-45	1.312" (33.32 mm)	1.50" (38.1 mm)
SU 0051	533/328-33	1.623" (41.22 mm)	1.50" (38.1 mm)
SU 0048	Kilian 25/32	1.3770" (34.97 mm)	0.985" (25.01 mm)
SU 0050	Kilian 20/28	1.1805" (29.98 mm)	0.9842" (25 mm)
SU 0049	DD2-31	1.50" (38.1 mm)	1.25" (31.75 mm)
SU 0053	DS3	2.0" (50.8 mm)	1.125" (28.57 mm)
SU 0036	DD2/DDS2	2.124" (53.94 mm)	1.50" (38.1 mm)

BLANK DIES

Use to block die pockets in unused stations.

- Required to run a partial set of tooling



BLANK DIES

Part No.	Application	Size
SU 7725	BD-1 "BB"	0.945 x 0.875" (24 x 22.22 mm)
SU 7726	BD-2 "B"	1.1875 x 0.875" (30.16 x 22.22 mm)
SU 7727	BD-3 "D"	1.50 x 0.9375" (38.1 x 23.81 mm)
SU 7728	BD-4 "DS3"	2.0 x 1.25" (50.8 x 31.75 mm)
SU 7729	BD-5 "533/328-45"	1.3125 x 1.50" (33.33 x 38.1 mm)
SU 7730	BD-6 "533/328-33"	1.6245 x 1.50" (41.26 x 38.1 mm)
SU 7731	BD-7 "DD2-23"	2.125 x 1.50" (53.97 x 38.1 mm)
SU 7732	BD-8 "EU-BBS"	0.8268 x 0.875" Korsch/Kilian (21 x 22.22 mm)
SU 7733	BD-9 "EU-BBS"	0.8661 x 0.875" Fette (22 x 22.22 mm)

PUNCH GUIDE PLUGS

Block auto-lubrication ports when blank dies are required. Natoli Punch Guide Plugs are safe, effective, and economical.



PUNCH GUIDE PLUGS

Part No.	Item Description	Punch Type
SU 0150	Keyed Punch Guide Plug	B
SU 0150M	Keyed Punch Guide Plug—Metric	B
SU 0151	Keyed Punch Guide Plug	D
SU 0151M	Keyed Punch Guide Plug—Metric	D

PUNCH GUIDE SEAL INSTALLATION TOOL

Ensures proper installation of seal to turret, avoiding potential damage due to improper punch guide seal installation. **Requires a Die Driving Rod (see page 16) for proper installation.**

PUNCH GUIDE SEAL INSTALLATION TOOL

Part No.	Item Description
SU 0400	"B" Punch Guide Seal Installation Tool
SU 0401	"D" Punch Guide Seal Installation Tool



Shown with punch guide seal

PUNCH SEAL REMOVAL TOOL

Easily remove tight punch seals from a turret.



PUNCH SEAL REMOVAL TOOL

Part No.	Item Description
SU 0193	Punch Seal Removal Tool

PRECISION STRAIGHT EDGE

Properly set feed frame platforms to ensure proper clearance.

- Constructed of tool steel
- Single beveled edge



PRECISION STRAIGHT EDGE

Part No.	Size
SU 0136	12 x 1 ¹³ / ₃₂ x 1 ¹¹ / ₆₄ " (304.8 x 35.71 x 4.34 mm)

LOWER PUNCH SEAL STOP INSTALLATION TOOL

Our custom seal stop tool, which is to be positioned between the lower punch head and turret, helps prevent damage to punch tips and dies during set-up.



MA 1114 In Use



LOWER PUNCH SEAL STOP INSTALLATION TOOL

Part No.	Item Description
MA 1114	Lower Punch Seal Stop Installation Tool

Each Lower Punch Seal Stop Installation Tool is custom made according to press. Photograph representation only and actual product may vary from image.

TIGHT PUNCH REMOVAL TOOL

The safest, most effective way to remove tight punches. Reduces potential for punch and turret damage.



TIGHT PUNCH REMOVAL TOOL

Part No.	Barrel Diameter	Punch Type
SU 0126	0.75" (19.05 mm)	B
SU 0128	1.0" (25.4 mm)	D
SU 0129	1.125" (25.58 mm)	328/533-45
SU 0130	1.25" (31.75 mm)	328/533-33 or DS3
SU 0132	1.50" (38.1 mm)	DD2 or DDS2



CAM ALIGNMENT PUNCHES

Tool is specially designed to ensure non-contact cam alignment with tooling, eliminating tablet press and tooling damage caused by misalignment.



CAM ALIGNMENT PUNCHES

Part No.	Punch Type
SU 0210	B
SU 0214	EU B
SU 0211	D
SU 0215	EU D
SU 0212	533/328-45
SU 0213	533/328-33
SU 0209	DD2-23
SU 0233	NP-100



TELESCOPING METAL INSPECTION MIRRORS

Inspect die pockets, hidden places, and other hard-to-see angles. The telescoping handle reaches from a range of 16–34" (406–863 mm).

- Shatterproof
- Protective bag included



TELESCOPING METAL INSPECTION MIRRORS

Part No.	Item Description	Size
IN 7542	Oblong Telescoping Inspection Mirror	2 x 3¾" (50.8 x 95.25 mm)
IN 7543	Round Telescoping Inspection Mirror	3¾" (95.25 mm)

STAINLESS STEEL SCOOP

316 grade stainless steel scoop for all types of granulation. Perfect for abrasive/corrosive granules.



STAINLESS STEEL SCOOP

Part No.	Capacity	Bowl Size
LE 3102	100 ml (3.4 oz.)	2 x 4" (50.8 x 101.6 mm)
LE 3103	500 ml (2 cups)	3¾ x 5½" (95.25 x 139.7 mm)
LE 3104	1250 ml (5 cups)	5 x 7⅝" (127 x 194.72 mm)

RIGHT ANGLE PNEUMATIC DRILL

Use with ultra-stiff nylon brushes (see page 47) to quickly and effectively clean die bores, turrets, and punch guides.



RIGHT ANGLE PNEUMATIC DRILL

Part No.	Item Description	Size
SU 0069	Right Angle Pneumatic Drill	⅜" ID Air Hose

PUNCH REPLACEMENT KEYS

Worn keys can damage punches and turrets, causing expensive repairs and downtime. Periodically replace keys to ensure proper alignment of keyed punches.

FIXED PARALLEL KEYS (FEATHER KEYS)

- Specify thread size when ordering



FIXED PARALLEL KEYS (FEATHER KEYS)

Part No.	Width x Length	Thread Size
MA 6147	⅜" x ⅞" (4.76 x 25 mm)	M3 x 0.5 mm
MA 6047	⅜" x 1" (4.76 x 25.4 mm)	M3 x 0.5 mm
MA 6048	⅜" x 1¼" (4.76 x 31.75 mm)	M3 x 0.5 mm
MA 6152	⅜" x 1⅜" (4.76 x 34.92 mm)	M3 x 0.5 mm
MA 6049	⅜" x 1½" (4.76 x 38.1 mm)	M3 x 0.5 mm
MA 6153	¼" x 1¼" (6.35 x 31.75 mm)	M4 x 0.7 mm

HI-PRO SCREW-IN KEYS

- Specify thread size when ordering



HI-PRO SCREW-IN KEYS

Part No.	Width x Length	Thread Size
MA 6155	⅜" x ¾" (4.76 x 19.05 mm)	M3 x 0.5 mm
MA 6156	¼" x 1" (6.35 x 25.4 mm)	M4 x 0.7 mm

HI-PRO PRESS-IN KEYS

- No threaded hole



HI-PRO PRESS-IN KEYS

Part No.	Width x Length
MA 7056	⅜" x ¾" (4.76 x 19.05 mm)
MA 6058	⅜" x 1" (4.76 x 25.4 mm)
MA 6060	¼" x 1" (6.35 x 25.4 mm)
MA 6062	⅝" x 1" (7.93 x 25.4 mm)

STAINLESS STEEL KEY SCREWS

- Secure key in punch body



STAINLESS STEEL KEY SCREWS

Part No.	Width x Length	Thread Size
MA 6207	12 mm	M3 x 0.5 mm
MA 6208	16 mm	M3 x 0.5 mm
MA 6209	20 mm	M3 x 0.5 mm
MA 6216	22 mm	M3 x 0.5 mm
MA 6210	25 mm	M3 x 0.5 mm
MA 6211	25 mm	M4 x 0.7 mm
MA 6212	30 mm	M4 x 0.7 mm
MA 6213	16 mm	M4 x 0.7 mm
MA 6215	16 mm (cut down head)	M4 x 0.7 mm

NATOLI TIP-MOUNTED DUST CUPS

Tip-mounted dust cups prevent lubricant contamination and black specks. Made with pharmaceutical-grade materials to meet requirements for stability, wear resistance, cleaning, and flexibility, tip-mounted dust cups require cutting a hole using the Natoli Dust Cup Cutting Tool (see page 23) or using the upper punch.

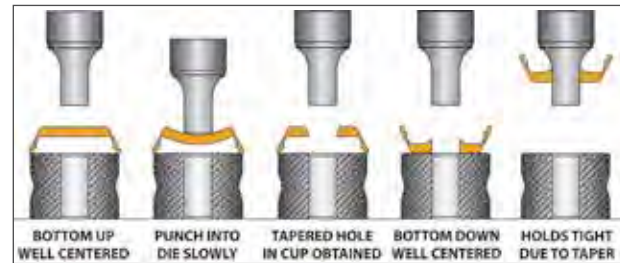

How to properly install Tip-Mounted Dust Cups without the Natoli Dust Cup Cutting Tool

ORIGINAL POLYMER TIP-MOUNTED DUST CUPS

Available in four outside diameter sizes and three colors

- **BB, B:** 1.000" (25.4 mm)
- **B, D:** 1.212" (30.79 mm)
- **D:** 1.349" (34.27 mm)
- **DS3:** 1.748" (44.4 mm)

ORIGINAL TIP-MOUNTED DUST CUPS		
Part No.	Size	Color
SU 2496	BB or B	Orange
SU 2501	BB or B	Clear
SU 2501AR	BB or B	Red
SU 2497	B or D	Orange
SU 2502	B or D	Clear
SU 2502AR	B or D	Red
SU 2498	D	Orange
SU 2503	D	Clear
SU 2499	DS3	Orange
SU 2504	DS3	Clear

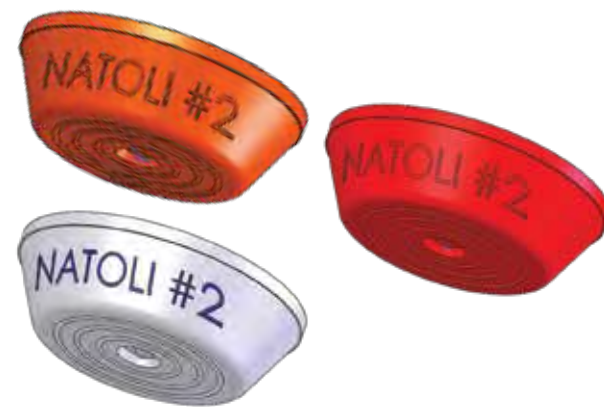

SILICONE TIP-MOUNTED DUST CUPS

Silicone dust cups have greater elasticity and a longer usage life. Metal detectable dust cups are infused with iron, which can be detected by even the strictest metal detectors.

- Can be left on tooling when washing in ultrasonic cleaners
- Withstands temperatures up to 500°F (260°C)

Available in three outside diameter sizes and four colors

- **BB, B:** 1.000" (25.4 mm)
- **B, D:** 1.212" (30.79 mm)
- **D:** 1.349" (34.27 mm)

SILICONE TIP-MOUNTED DUST CUPS		
Part No.	Size	Color
SU 2601	BB or B	Clear
SU 2601B	BB or B	Blue
SU 2601R	BB or B	Red
SU 2601MD	BB or B	Black (Metal Detectable)
SU 2602	B or D	Clear
SU 2602B	B or D	Blue
SU 2602R	B or D	Red
SU 2602MD	B or D	Black (Metal Detectable)
SU 2603	D	Clear
SU 2603B	D	Blue
SU 2603R	D	Red
SU 2603MD	D	Black (Metal Detectable)

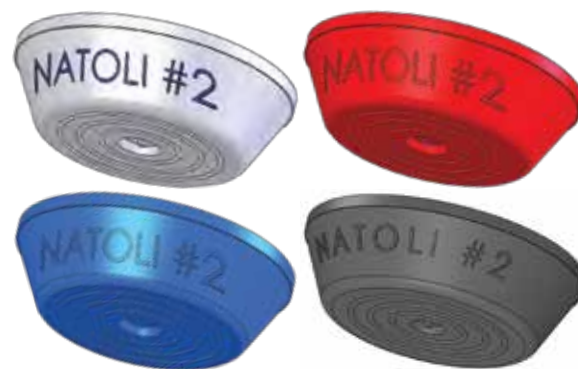

NEW STYLE THERMOPLASTIC TIP-MOUNTED DUST CUPS

- Recommended for use with segmented turrets
- Reduced cup angle helps in situations with clearance issues

Available in three outside diameter sizes and four colors

- **B:** 1.000" (25.4 mm)
- **D, 533/328-45:** 1.250" (31.75 mm)
- **533/328-33:** 1.750" (44.45 mm)



NEW STYLE TIP-MOUNTED DUST CUPS		
Part No.	Size	Color
SU 2802	B	White
SU 2802O	B	Orange
SU 2802B	B	Blue
SU 2802R	B	Red
SU 2803	D or 533/328-45	White
SU 2803O	D or 533/328-45	Orange
SU 2803B	D or 533/328-45	Blue
SU 2803R	D or 533/328-45	Red
SU 2804	533/328-33	White
SU 2804O	533/328-33	Orange
SU 2804B	533/328-33	Blue
SU 2804R	533/328-33	Red

NATOLI DUST CUP CUTTING TOOL

No longer cut dust cups on a tablet press. Use the Natoli Dust Cup Cutting Tool to safely and accurately punch out dust cups for tip-mounting your production tooling.

- **Easy, fast set-up**
- Bottom-up design requires less space and can be placed on almost any work surface
- Lightweight—move without additional equipment
- Acetal dust cup slides can be custom made for any size dust cup

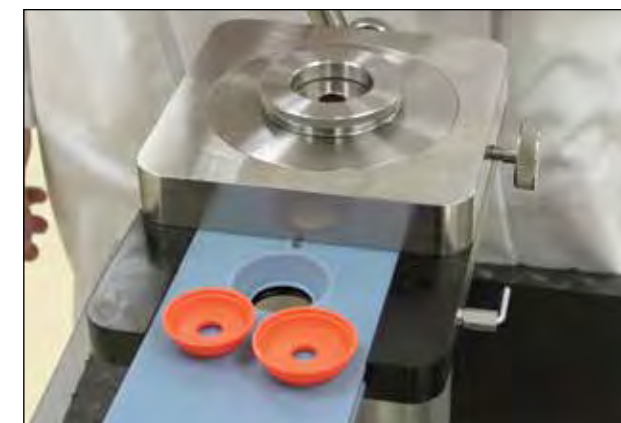

The Dust Cup Cutting Tool (SU 8000) in use



NATOLI DUST CUP CUTTING TOOL	
Part No.	Item Description
SU 8000	Dust Cup Cutting Tool

NATOLI BARREL-STYLE DUST CUPS

Prevent lubricant contamination and black specks with Barrel-Style Dust Cups. Made with pharmaceutical-grade materials to meet specific requirements for stability, wear resistance, cleaning, and flexibility, barrel-style dust cups include pre-cut holes to fit directly on a punch barrel with or without upper punch dust cup grooves.

ORIGINAL POLYMER BARREL-STYLE DUST CUPS

Available in two outside diameter sizes and two colors

- **B:** 1.078" (27.38 mm)
- **D:** 1.4375" (36.51 mm)

ORIGINAL BARREL-STYLE DUST CUPS

Part No.	Size	Color
SU 2506	B	White
SU 2493	B	Orange
SU 2507	D	White
SU 2494	D	Orange



SILICONE BARREL-STYLE DUST CUPS

Silicone dust cups have greater elasticity and a longer usage life. Metal detectable dust cups are infused with iron, which can be detected by even the strictest metal detectors.

- Can be left on tooling when washing in ultrasonic cleaners
- Withstands temperatures up to 500 °F (260 °C)

Available in three outside diameter sizes and five colors

- **B:** 1.078" (27.3812 mm)
- **D:** 1.4375" (36.51 mm)
- **Natoli FS12 Type:** 0.700" (17.78 mm)

SILICONE BARREL-STYLE DUST CUPS

Part No.	Size	Color
SU 2612	B	Clear
SU 26120	B	Orange
SU 2612B	B	Blue
SU 2612R	B	Red
SU 2612MD	B	Black (Metal Detectable)
SU 2613	D	Clear
SU 26130	D	Orange
SU 2613B	D	Blue
SU 2613R	D	Red
SU 2613MD	D	Black (Metal Detectable)
SU 2605	Natoli FS12 Type	Clear
SU 26050	Natoli FS12 Type	Orange
SU 2605B	Natoli FS12 Type	Blue
SU 2605R	Natoli FS12 Type	Red
SU 2605MD	Natoli FS12 Type	Black (Metal Detectable)



NEW STYLE THERMOPLASTIC BARREL-STYLE DUST CUPS

Available in two outside diameter sizes and four colors

- **B:** 1.000" (25.4 mm)
- **D:** 1.250" (31.75 mm)



Barrel-Style Dust Cups in use

NEW STYLE BARREL-STYLE DUST CUPS

Part No.	Size	Color
SU 2812	B	White
SU 28120	B	Orange
SU 2812B	B	Blue
SU 2812R	B	Red
SU 2813	D	White
SU 28130	D	Orange
SU 2813B	D	Blue
SU 2813R	D	Red

NATOLI EU1/441 BARREL-STYLE DUST CUPS

Natoli EU1/441 barrel-style dust cups are made with pharmaceutical-grade materials, which are selected to meet specific requirements for stability, wear resistance, cleaning, and flexibility. Helps prevent lubricant contamination and black specks on tablets.



EU1/441 BARREL-STYLE DUST CUPS

Part No.	Size	Color
SU 2800	EU1/441	White

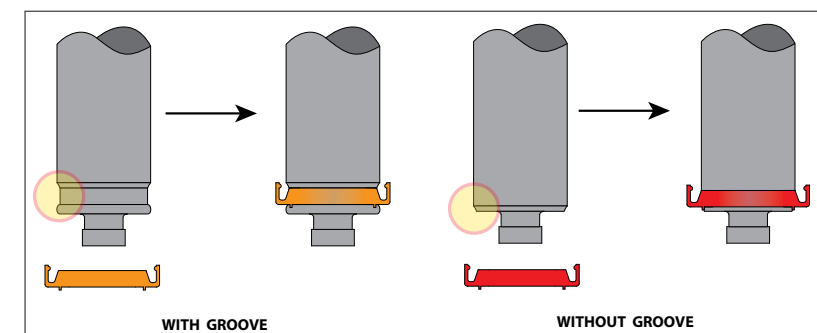

How to properly install Barrel-Style Dust Cups

NATOLI SILICONE BELLOWS

For use on upper punches with a bellows groove, silicone bellows eliminate dust on punch barrels, reducing friction and enhancing lubrication performance.



MUST HAVE!

NATOLI SILICONE BELLOWS	
Part No.	Punch Type
SU 2511	B
SU 2511-S	B Firm Type
SU 2511MD	B Metal Detectable
SU 2513	D
SU 2513-S	D Firm Type
SU 2513MD	D Metal Detectable



SU 2511 in use

EURO-STYLE SILICONE BELLOWS AND RETAINING RING

Euro-style designed bellows for use on punches with an optional retaining ring for Fette and Kilian tablet presses. Silicone bellows eliminate dust on punch barrels, reducing friction and enhancing lubrication performance.

EURO-STYLE SILICONE BELLOWS AND RETAINING RING	
Part No.	Punch Type
SU 2615	B Euro-Style Bellow
SU 2615MD	B Euro-Style Metal Detectable Bellow
SU 2616	B Euro Retaining Ring
SU 2617	D Euro-Style Bellow
SU 2617MD	D Euro-Style Metal Detectable Bellow
SU 2618	D Euro Retaining Ring



COMPRESSION SUPPORT EQUIPMENT

Support tablet production with a variety of auxiliary products that keep tablet presses in good working order and ensure tablets meet quality standards. **Dedusters** and **industrial vacuums** maintain tablet quality and press performance by removing dust from tablets and presses. **Metal detectors** identify contamination caused by mixing-process errors or machinery failures.



Telescopic Deduster
Part No. SU 2794



Lock Insight PH
Metal Detector
Part No. MA 0323



VHW321 3-Phase
Vacuum System
Part No. SU 2902

NATOLI UPHILL TABLET DEDUSTER

This deduster performs elevating and dedusting processes simultaneously. Ultra-high-speed, it is well-suited for pharmaceutical, nutraceutical, chemical, foodstuff and related applications.

FEATURES:

- High-quality, stainless steel construction
- Variable speed control
- Long dedusting path
- Automatic polishing of all sides/angles

EXTERIOR DIMENSIONS (L X W X H):

- 20 x 22 x 53" (500 x 550 x 1350 mm)

SPECIFICATIONS:

- **Deduster Distance:** 20.3' (6.0 m)
- **Maximum Tablet Diameter:** 1" (25 mm)
- **Feeding Height:** 33–39" (835–985 mm)
- **Adjustable Chute:** 42–48" (1.07–1.22 m)
- **Clean Compressed Air:** 0.1 CMM, 0.05MPa
- **Vacuum:** 2.7 CMM, –0.1MPa
- **Power Supply:** 110v or 220v, 50 Hz



NATOLI UPHILL TABLET DEDUSTER

Part No.	Item Description	Voltage	Maximum Throughput
SU 2894	Uphill Tablet Deduster	110v	1,000,000 (8 mm tablets)
SU 2895	Uphill Tablet Deduster	220v	1,000,000 (8 mm tablets)

STAINLESS STEEL TABLET DEDUSTER

Mirror-polished 304 stainless steel with adjustable base, variable speed vibrator and an adjustable inlet funnel, along with washdown motor and controls.

FEATURES:

- Vibrator and controls are built to NEMA washdown specifications
- All mirror-polished stainless steel contact parts and exterior covers
- Adjustable tilt feature, when set in relation to vibration intensity, determines speed of tablets
- GMP designs and construction
- Quick disconnect clear Lexan® top cover
- Stainless steel support column
- Stainless steel vacuum nozzle for dust control
- 5-leg polished aluminum base with locking casters

SPECIFICATIONS:

- **Electrical:** 110v, 1ph, 60 Hz
- **Air:** 1–2 CFM (0.03–0.06 CMM)
- **Vacuum:** 20–30 CFM (0.6–0.9 CMM)
- **Net Weight:** 36 lb. (16.3 kg)
- **Shipping Weight:** 50 lb. (22.7 kg)



STAINLESS STEEL TABLET DEDUSTER

Part No.	Item Description	Voltage	Maximum Throughput
SU 2893	Standard Electric	110v	180,000

KRÄMER DRUM-STYLE TABLET DEDUSTER

FEATURES:

- Acrylic glass housing
- Dedusting and deburring capabilities
- Adjustable vibration
- Toolless assembly/disassembly
- Low maintenance
- GMP compliant

DIMENSIONS:

- **Required Floor Area:** 12.4" ø (315 mm ø)
- **Adjustable Overall Height (with stand):** 35.8–39.2" (910–995 mm)
- **Adjustable Inlet Height (with stand):** 27.6–35.8" (700–910 mm)

SPECIFICATIONS:

- **Downward Conveying Range:** 12" (300 mm)
- **Conveying of Tablets/Capsules:** 0.20–1" (5–25 mm) ø
- **Power Supply:** 110v or 230v, 50/60 Hz



KRÄMER DRUM-STYLE TABLET DEDUSTER

Part No.	Item Description	Maximum Throughput
SU 2790	Standard Drum-Style Deduster	3,000,000 (5 x 2 mm) tablets

KRÄMER TELESCOPIC TABLET DEDUSTER

This telescopic tablet deduster has improved dedusting and deburring capabilities thanks to an optimized combination of vibration, dust agitation, and air/vacuum suction. It is also equipped with an acceleration sensor that ensures constant vibration, independent of the load or the amount of tablets in the deduster.

FEATURES:

- Dedusting and deburring capabilities
- Toolless assembly and disassembly
- Acceleration sensor
- Vibration-free housing
- GMP compliant

SPECIFICATIONS:

- **Outlet Height:** 39–49" (990–1235 mm)
- **Inlet Height:** 28–38" (715–960 mm)
- **Upward Conveying Range:** 10–20" (250–500 mm)
- **Conveying of Tablets/Capsules:** 0.12–1" (3–25 mm) ø
- **Power Supply:** 100–240v, 50/60 Hz

EXTERIOR DIMENSIONS (L X W X H):

- 22 x 22 x 56" (563 x 563 x 1425 mm)—Adjustable Height



KRÄMER TELESCOPIC TABLET DEDUSTER

Part No.	Item Description	Maximum Throughput
SU 2794	Telescopic Tablet Deduster	3,500,000 (4.8 x 2.3 mm) tablets

KRÄMER COMBINED UNIT (TABLET DEDUSTER + METAL DETECTOR)

Maximum Throughput = 3,500,000 TPH

This tablet deduster and metal detector saves valuable production time by combining two steps into one. These machines may be used on either side of a tablet press or capsule filling facility.

METAL DETECTOR FEATURES:

- 21 CFR Part 11 compliant
- Fail-safe operation mode
- Waterproof and dust tight
- Functions with gravity
- Four safety levels
- Battery-driven permanent storage
- 100-product memory

TABLET DEDUSTER FEATURES:

- cGMP compliant
- Upward vibratory conveying
- Conveying range of 250–500 mm
- Integrated acceleration sensor
- Large viewing window
- No tools required



DIMENSIONS (L X W X H):

- 32.7 x 22.6 x 56" (830 x 575 x 1425 mm)

KRÄMER COMBINED UNIT (TABLET DEDUSTER + METAL DETECTOR)

Part No.	Deduster	Metal Detector	Aperture Diameter
SU 2693	Kraemer KD6015	Safeline Table x 2	95 x 38 mm
SU 2697	Kraemer KD6015	with Lock	95 x 38 mm
SU 2698	Kraemer KD6015	with Ceia Metal Detector	95 x 38 mm

LOCK INSIGHT PH PHARMACEUTICAL METAL DETECTOR

The Lock Insight PH Metal Detector was made for the pharmaceutical industry. Innovative features provide superior quality assurance while meeting GMP standards.

MAXIMUM THROUGHPUT:

- 30,000 TPM or 1,800,000 TPH

FEATURES:

- Fail-safe operating mode
- Color touchscreen with 200 product presets
- External USB and other communication methods
- Direct digital signal vector diagram display
- Four password-protected security levels
- IQ/OQ/PQ validation documents and certification included
- Calibrated detection levels of 0.25mmFE, 0.3 mmNFE, and 0.4mm/St

PHYSICAL FEATURES:

- Compact footprint
- Adjustable height/head angle
- Easy-clean, hygienic design



LOCK INSIGHT PH PHARMACEUTICAL METAL DETECTOR

Part No.	Item Description
LE 0323	Lock Insight PH Metal Detector

VACUUM SYSTEMS FOR DUST CONTAINMENT

Industrial vacuums deliver all the features you need to remove dust from the environment and from your processing equipment and meet manufacturers' requests for use in areas where hygiene and reliability are essential. Powerful motors with quiet sound pressure levels and advanced filtration efficiently collect and contain large amounts of fine powders. HEPA and ULPA filters ensure contaminant-free exhaust.

STAINLESS STEEL INDUSTRIAL VACUUM

- Easy filter cleaning with PullClean technology while vacuum is running
- Sold with anti-static hose, cuff and inlet coupler

SPECIFICATIONS:

- **Airflow:** 150 CFM (4.24 CMM)
- **Waterlift:** 88" (2.235 m)
- **Container Capacity:** 6.6 gal. (25 L)



SU 2900

STAINLESS STEEL INFINICLEAN™ INDUSTRIAL VACUUM

- InfiniClean™ automatic filter cleaning system cleans the filter without human interaction
- Sold with anti-static hose, cuff and inlet coupler

SPECIFICATIONS:

- **Airflow:** 150 CFM (4.24 CMM)
- **Waterlift:** 88" (2.235 m)
- **Container Capacity:** 6.6 gal. (25 L)



SU 2902



SU 2903

VHW321 3-PHASE VACUUM SYSTEM

- Pharma Series designed for white rooms
- Easy filter cleaning with PullClean technology while vacuum is running

SPECIFICATIONS:

- **Airflow:** 150 CFM (4.24 CMM)
- **Waterlift:** 88" (2.235 m)
- **Container Capacity:** 6.6 gal. (25 L)

VHW421 3-PHASE VACUUM SYSTEM

- Pharma Series designed for white rooms
- Easy filter cleaning with PullClean technology while vacuum is running
- Downstream HEPA filter standard with stainless steel collection container

SPECIFICATIONS:

- **Airflow:** 222 CFM (6.28 CMM)
- **Waterlift:** 76" (1.93 m)
- **Container Capacity:** 12.6 gal. (47.69 L)

VACUUM SYSTEMS FOR DUST EXTRACTION/CONTAINMENT

Part No.	Item Description
SU 2900	Nilfisk Stainless Steel Industrial Vacuum
SU 2901	Nilfisk InfiniClean™ Industrial Vacuum (not shown)
SU 2902	Nilfisk VHW321 3-Phase Vacuum System—Whiteline Series
SU 2903	Nilfisk VHW421 3-Phase Vacuum System—Whiteline Series

PORTABLE DRY/WET DUST EXTRACTING VACUUM

Nilfisk ATTIX 33 dust extractor vacuum with InfiniClean™ automatic filter cleaning and automatic tool start is ideal for dust control in polishing machines and other pharmaceutical processes. It provides versatility with a small footprint but high performance.

FEATURES:

- **Container Capacity—Dry:** 8 gal. (30 L)
- **Container Capacity—Wet:** 5.2 gal. (19.5 L)
- **Airflow:** 148 CFM (4.19 CMM)
- **Waterlift:** 92" (2.337 m)
- **Hose/Tube Diameter:** 1.25" (32 mm)
- **Sound Pressure Level:** Quiet 69 dB(A)

DIMENSIONS (L X W X H):

- 32 x 16 x 25" (800 x 400 x 640 mm)

SHIPPING WEIGHT:

- 45 lb. (20.5 kg)



PORTABLE DRY/WET DUST EXTRACTING VACUUM

Part No.	Item Description
SU 2904	Nilfisk ATTIX 33-21 Dry/Wet Vacuum

PORTABLE 3VT PNEUMATIC CONVEYOR

Transfer your product without market segregation! The 3VT pneumatic conveyor moves powder and granules from sacks, big bags or other containers to the required location in selected quantities and within the desired time. Nilfisk's specialized process takes place in perfect hygienic conditions, respecting both the environment and the operator's health.

FEATURES:

- **Throughput:** 100–500 kg/hour
- **Power:** 220v at 0.94 HP
- **Airflow:** 9.4–14.7 CFM (0.26–0.41 CMM)
- **Waterlift:** 291" (7.39 m)
- **Hopper Capacity:** 2.9 gal. (10.97 L)
- **Inlet Air Pressure (min./max.):** 60–90 psi

DIMENSIONS (L X W X H):

- 40 x 18 x 120" (1016 x 457.2 x 3048 mm)

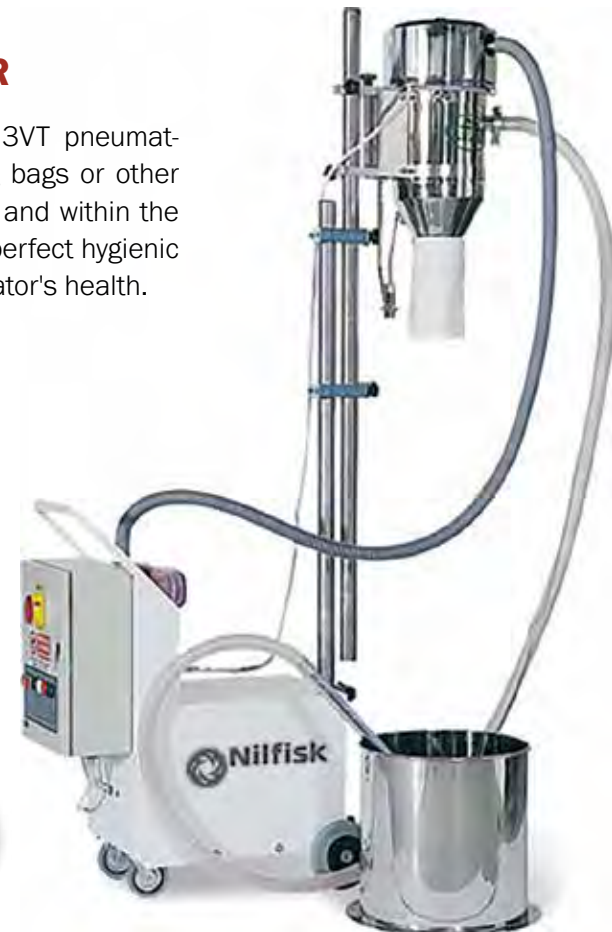

PORTABLE 3VT PNEUMATIC CONVEYOR

Part No.	Item Description
SU 2905	3VT Pneumatic Conveyor



QUALITY ASSURANCE

Quality assurance is essential to any pharmaceutical process. Collect accurate, repeatable measurements of various tablet characteristics, including disintegration, dissolution, friability and hardness, with Natoli's quality assurance products. Our **3-in-1 Tablet Hardness and Thickness Tester** accurately calculates the hardness, thickness, diameter and length of solid dosage forms, determining the mechanical integrity of a tablet.



Manual 3-In-1 Tablet Hardness & Thickness Tester
Part No. LE 0642



Precision Balance
Part No. LE 0595

TABLET HARDNESS TESTERS

Tablet hardness testers are used to perform spot checks of tablet density during initial setup and production runs.

STAINLESS STEEL HANDHELD TABLET HARDNESS TESTER*

When new, this tablet hardness tester has an accuracy of $\pm 10\%$.

TABLET TESTING RANGE	MAX DIAMETER	MAX THICKNESS
Standard Hardness Tester	3/4" (19.05 mm)	1/4" (6.35 mm)
Large Tablet Conversion Kit	1 5/16" (30.1 mm)	1/4" (6.35 mm)

- SPECIFICATIONS:**
- **Measuring Units:** Kg



STAINLESS STEEL HANDHELD TABLET HARDNESS TESTER

Part No.	Item Description
SU 2495	Standard Hardness Tester
SU 2491	Large Tablet Conversion Kit

*Handheld tester should be used as a reference to hardness and not for quality control judgments. It should not be relied on as a test instrument.

PORTABLE HANDHELD TABLET HARDNESS TESTER

Offers the convenience of measuring tablet hardness outside the lab.

- FEATURES:**
- Battery operated (includes charger)
 - Automatic zero reading on start up
 - Collection tray
 - Adjustable shoulder strap (optional)

- SPECIFICATIONS:**
- **Hardness Range:** up to 500N
 - **Measuring Units:** N, Kp, SC or lb
 - **Tablet Size:** 2-28 mm (length/diameter)
 - **Power:** 1.9v rechargeable battery/universal adapter



PORTABLE HANDHELD TABLET HARDNESS TESTER

Part No.	Item Description
LE 0645	Portable Hardness Tester with Printer Port
LE 0646	Printer Accessory
LE 0647	Calibration Weight Set



MANUAL 3-IN-1 STAINLESS STEEL TABLET HARDNESS & THICKNESS TESTER

An economical, simple-to-use hardness tester that immediately makes contact with tablet to measure hardness, thickness, diameter, and length of solid dosage forms.

- FEATURES:**
- Touch-screen display
 - Capable of up to 250 samples per test
 - Electronic load-cell
 - Adjustable break between samples
 - Constant force and constant speed measuring principles available as standard
 - Programmable calibration and verification modes
 - Auto/manual mode with programmable time delay
 - Printing (serial/ethernet) for data and graph selectable—RS232 Serial

- SPECIFICATIONS:**
- **Diameter/Thickness:** ± 0.02 mm
 - **Range:** 10–500N
 - **Accuracy:** ± 1 N
 - **Hardness:** ± 1 N
 - **Units:** N, Kp, Sc



MANUAL 3-IN-1 STAINLESS STEEL TABLET HARDNESS & THICKNESS TESTER

Part No.	Item Description
LE 0642	Tabletop Hardness Tester
LE 0624	Printer
LE 0647	Calibration Weight Set

INFRARED LASER THERMOMETER

Use a non-contact infrared laser thermometer to determine the temperature zone when tablets may start to film and/or stick to the punch face. This type of thermometer is recommended for troubleshooting and discovering the heat limits of sensitive products. It also accurately measures tablet press tooling, cam tracks and pressure roller temperatures. Recorded data can be stored in a log for future reference. *Two AAA batteries included.*

- FEATURES:**
- Circle laser for better targeting
 - -58 – 1022 °F (-50 – 550 °C)
 - High-quality 12:1 optics
 - Reads type K probes
 - Adjustable emissivity
 - Max/Min, C/F, Avg, Alarm



INFRARED LASER THERMOMETER

Part No.	Item Description	Accuracy
SU 0370	Infrared Laser Thermometer	± 1.8 °F (± 1.0 °C)*

*Accuracy can be affected by the emissivity setting, target spot size, and rapid changes in ambient temperature.

FRIABILITY TESTER

This friability tester reliably predicts the tablet robustness. The stainless steel housing ensures it will fit well in your production area, and the tester is manufactured in compliance to the USP, EP and other pharmacopoeias.

FEATURES:

- Programmable counter/timer
- Two modes—time and revolution count
- RPM and count validation
- IQ/OQ documents included
- 10° tilt capability (optional)

SPECIFICATIONS:

- **Speed:** 25 RPM
- **Accuracy:** ±1 RPM
- **Number of Drums:** Two front loading

DIMENSIONS (W X D) BASE FOOTPRINT:

- 13.8 x 12.2" (350.525 x 309.88 mm)



FRIABILITY TESTER

Part No.	Item Description
LE 0631	Dual-Drum Fixed-Speed Friability Tester
LE 0690	Right Standard Replacement Drum
LE 0691	Left Standard Replacement Drum

DUAL-STATION DISINTEGRATION TESTER

This semi-automated tablet disintegration tester enables the entry and recall of stored methods for both testing positions. The baskets can start and stop independently and will always be moved to the upper position outside the disintegration media. Edit product and test information easily on the large LCD screen and an alpha-numerical keyboard. Security and results reporting meets FDA requirements.

FEATURES:

- OQ/PQ monitoring (programmable time sequence information)
- Test and sample information filing for up to 16 methods
- Auto-basket-stop of disintegration times
- Thermostat safety control
- RS-232 and parallel printer interface
- Built-in basket lift

SPECIFICATIONS:

- **Thermostat:** 86–104°F, ±0.3°F (25–45°C, ±0.3°C)
- **Stroke Frequency:** 30/minute
- **SF Accuracy:** ±1 stroke
- **Stroke Height:** 2", ±0.08" (55 mm, ±1 mm)
- **Power:** 230v, 50/60 Hz

DIMENSIONS (H X W X D):

- 22.4 x 23.75 x 14.375" (570 x 603.25 x 365 mm)



DUAL-STATION DISINTEGRATION TESTER

Part No.	Item Description
LE 0639	Semi-Auto Dual-Station Disintegration Tester
LE 0624	Printer

ANALYTICAL BALANCE

This analytical balance features internal calibration with the option to use external calibration weight. The innovative design results in a compact footprint, so the balance occupies minimal space on the laboratory workbench while retaining a high level of performance. In addition to its 100 gram maximum weighing capacity and 0.0001 gram readability, this analytical balance features a glass-weighing chamber and a 3.54" ø (90 mm ø) weighing pan.

FEATURES:

- 14 weighing units, plus a custom setting
- Simple, user-friendly operation
- Multilingual display
- Vivid, back-lit LCD display with 0.94" (24 mm) high digits easily visible in any lighting conditions
- Large stainless steel pan for easy cleaning
- Solid metal housing
- Non-slip adjustable leveling feet
- Overload protection helps prevent damage to internal components
- RS-232 and USB interface
- External calibration allows for verification and adjustment with weights
- Printouts include date and time for data tracking within Good Laboratory Practices (GLP) guidelines

APPLICATIONS:

- Weighing
- Parts counting
- Percentage weighing
- Check weighing
- Density determination
- Weight accumulation
- Formulation

DIMENSIONS (W X D X H):

- 8.7 x 13.4 x 13.5" (220 x 340 x 344 mm)



ANALYTICAL BALANCE

Part No.	Item Description
LE 0591	Analytical Balance

PRECISION BALANCE

A large 4.7" \varnothing (120 mm \varnothing) weighing pan, brilliant oversized display, and intuitive operation make this durable digital balance easy to use. With a readability of only 0.001 gram and a capacity of 220 grams, this balance is your ideal choice for balance-related needs.

FEATURES:

- 16 weighing units, plus custom setting
- Simple user-friendly operation
- Large back-lit LCD display with 0.8" (20 mm) high digits
- Large stainless steel pan for easy cleaning
- Capacity tracker built into display for easily monitoring possible overloads
- Removable draft shield helps reduce errors caused by air currents
- Printouts include date and time for data tracking within Good Laboratory Practices (GLP) guidelines
- RS-232 and USB Interfaces for computers and printers
- Level indicator and non-slip adjustable leveling feet
- IQ/OQ documents included
- External calibration

APPLICATIONS:

- Weighing
- Parts counting
- Percentage weighing
- Check weighing
- Density determination
- Weight accumulation

DIMENSIONS (W X D X H):

- 8.7 x 12.2 x 10.6" (220 x 310 x 270 mm)



PRECISION BALANCE

Part No.	Item Description
LE 0595	Precision Balance



CLEANING

Clean tools are critical to producing quality tablets, while a lack of cleanliness is the leading cause for tablet press failure, insufficient tablet quality, and discoloration (black specks). **Natoli's Stainless Steel 3-Piece Ultrasonic Cleaning System** has a cleaning cycle that can be completed in 20 minutes or less and provides a controlled consistency validating the cleaning process.

Stainless Steel 3-Piece
Ultrasonic Cleaning System
Part No. MA 7640



BEFORE ULTRASONIC CLEANING



AFTER ULTRASONIC CLEANING

Tabletop Ultrasonic
Cleaning Unit
Part No. MA 6100

NATOLI STAINLESS STEEL 3-PIECE ULTRASONIC CLEANING SYSTEM

Safely and efficiently clean your tooling with the user-friendly and cost-effective Natoli 3-Piece Ultrasonic Cleaning System. The convenient side-by-side design makes transferring punches and dies quick and easy, reducing the risk of tool damage during handling. **Units are CE approved.**

FEATURES:

- Space-saving bi-fold tank covers
- Easy-access front controls
- Adjustable thermostats with digital display
- Automatic dryer shut-off
- Illuminating runtime cycle switch
- All stainless steel construction with adjustable legs
- Sold as a set or individually
- Meets all FCC regulations

DIMENSIONS (W X D X H):

- **Overall:** 32 x 30 x 34.75" (812.8 x 762 x 882.65 mm)
- **Each Tank:** 24 x 16 x 14" (609.6 x 406.4 x 355.6 mm)



PLEASE REFER TO NATOLI.COM FOR MOST CURRENT MODEL. UPGRADES AND MODIFICATIONS AVAILABLE UPON REQUEST.

3-PIECE ULTRASONIC CLEANING SYSTEM

Part No.	Item Description	Power Requirements
MA 7640	3-Piece Ultrasonic Cleaning System	240v
MA 7643	Individual Ultrasonic Wash Unit with Filtration	240v/60 Hz/1 Phase/15 Amps
MA 7641	Individual Ultrasonic Rinse Unit	240v/60 Hz/1 Phase/10 Amps
MA 7642	Individual Ultrasonic Drying Unit	240v/60 Hz/1 Phase/18 Amps



TABLETOP ULTRASONIC CLEANING UNIT

Eliminate manual washing of individual tooling in this affordable tabletop ultrasonic cleaning unit. This wash unit delivers alternating phases of high and low pressure waves to efficiently remove oils, grease, oxides, and particulates. **Units are CE approved.**

FEATURES:

- 7 gal. (26.1 L) tank capacity
- ETL/CSA approved
- Precisely control time, heat, and power
- Includes a cover and basket

DIMENSIONS

- **Exterior Dimensions:** 21 x 12.75 x 14.5" (533 x 324 x 368 mm)
- **Tank Dimensions:** 19.5 x 11.75 x 8" (495 x 299 x 203 mm)



TABLETOP ULTRASONIC CLEANING UNIT

Part No.	Item Description	Voltage
MA 6100	Ultrasonic Tabletop Unit	115
MA 6101	Ultrasonic Tabletop Unit	230

DIGITAL IMMERSION THERMOMETER

Prevent damage and discoloration of tooling by testing water temperature in ultrasonic cleaning units. For optimum cleaning conditions, use a water temperature of 115–125° F (46–51° C). **Never exceed 150° F (65° C).**

FEATURES:

- -40–302° F (-40–150° C)
- Accuracy of ±1.8° F (±1° C)
- Rubberized switch panel
- 6-second response



DIGITAL IMMERSION THERMOMETER

Part No.	Item Description
MA 5112	Digital Immersion Thermometer

STAINLESS STEEL TOOLING TRAYS FOR ULTRASONIC CLEANERS

Reduce the risk of potential tool damage with Natoli Stainless Steel Tooling Trays, by providing secure handling from tablet press to cleaning system to storage. The tray is designed with folding handles and rubber-tipped legs.

FEATURES:

- Recommended for use with **ANY** Natoli Ultrasonic Cleaning Unit

TRAY CAPACITIES:

- **"B" Tray:** 72 "B" punches and 38 "B" dies or 72 "B" punches and 48 "BB" dies
- **"D" Tray:** 48 "D" punches and 24 "D" dies
- **"Natoli FS12 Type" Tray:** 72 punches

EXTERIOR DIMENSIONS (L X W X H):

- 17 x 10 x 5" (432 x 254 x 127 mm)

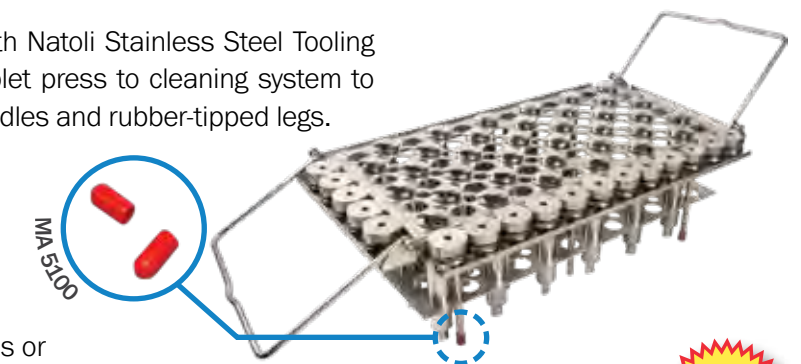

STAINLESS STEEL TOOLING TRAYS

Part No.	Item Description
MA 5082	Punch Tray for "B" Tooling
MA 5084	Punch Tray for "D" Tooling
MA 5087	Punch Tray for "Natoli FS12 Type" Tooling
MA 5100	Replacement Tips for Punch Tray



TOOLING TRAYS FOR ULTRASONIC CLEANERS

STAINLESS STEEL WIRE TOOLING BASKETS

Individual punch and die baskets are ideal for use in ultrasonic washing, rinsing and drying units.

- Stackable
- Sturdy, 316L stainless steel construction
- Economical

TRAY CAPACITIES:

- **“B” Punch Tray:** 55 punches
- **“B” Die Tray:** 50 dies
- **“D” Punch Tray:** 36 punches
- **“D” Die Tray:** 36 dies

EXTERIOR DIMENSIONS (L X W X H):

- 17 x 8 x 5" (432 x 203.2 x 127 mm)

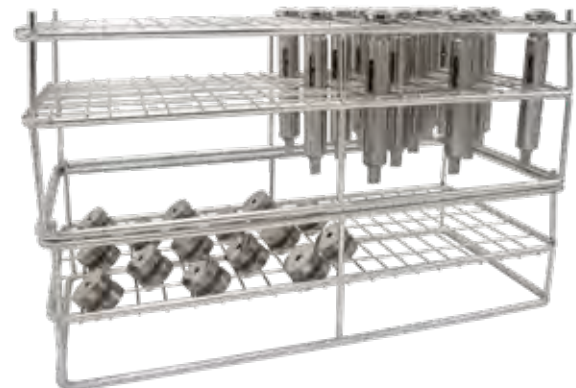

MA 7533 and MA 7534 shown stacked together for efficient cleaning



STAINLESS STEEL WIRE TOOLING BASKETS

Part No.	Item Description
MA 7533	Stainless Steel Punch Basket for “B” Tooling
MA 7534	Stainless Steel Die Basket for “B” Tooling
MA 7535	Stainless Steel Punch Basket for “D” Tooling
MA 7536	Stainless Steel Die Basket for “D” Tooling

MULTI-PURPOSE TOOLING STORAGE BOX TRAYS

The easiest tooling tray yet, from the cleaning unit to the storage box! Molded keyways and guides prevent tooling damage and allow for effortless transfer of tooling to the Natoli Tooling Storage Box Trays. An optional handle and leg kit allows the tooling tray to function separately from Natoli Tooling Storage Boxes (see page 88) without compromising tool safety. Available in three colors for easy identification.

- Perfect for use in Natoli’s Ultrasonic Cleaning Units (see pages 40–41), as well as transporting
- Trays have drainage holes for water to escape
- Punches and dies can be stored together in sets
- Head support for easy tool removal

TRAY CAPACITIES:

- **“B” Tray:** 72 “B” punches and 38 “B” dies or 72 “B” punches and 48 “BB” dies
- **“D” Tray:** 48 “D” punches and 24 “D” dies
- **533/328-45 Tray:** 45 punches and 24 dies
- **533/328-33 Tray:** 33 punches and 24 dies



TOOLING STORAGE BOX TRAYS

Part No.	Item Description	Color
MA 5184	“B” Tray	Cream
MA 5184R	“B” Tray	Red
MA 5184B	“B” Tray	Black
MA 5185	“B” Handle Kit	—

TOOLING STORAGE BOX TRAYS

Part No.	Item Description	Color
MA 5186	“D” Tray	Cream
MA 5186R	“D” Tray	Red
MA 5186B	“D” Tray	Black
MA 5187	“D” Handle Kit	—



CLEANING SOLUTIONS FOR ULTRASONIC CLEANERS

Natoli’s line of recommended cleaning solutions are specially formulated for use in ultrasonic cleaners (see pages 40–41). They were chosen through first-hand experience to yield the best possible cleaning results. All solutions are available in a one gallon container (3.8 L).

NATOLI ALKALINE WASH SOLUTION

Ultrasonic liquid detergent concentrate developed for cleaning tooling. Use as a standalone cleaner or as an alkaline wash solution booster.

- Removes oils, grease, particulate matter, and other contaminants
- Safe on steels, ceramic, glass, and more
- USDA Category A1

CHEM-CREST® 25 WASH SOLUTION

A non-ammoniated, general purpose, caustic-free alkaline ultrasonic cleaning solution. It is aqueous, heavy-duty, and biodegradable.

- Provides rapid, effective and efficient removal of various surface contaminants such as light oils, grease, fingerprints, and particulates
- Safe on aluminum, magnesium, stainless steel, glass, plastics, ceramics, copper, and brass



MA 6026



MA 6023

CHEM-CREST® 211 WASH SOLUTION

A multipurpose, heavy-duty, biodegradable, phosphate- and caustic-free, concentrated alkaline cleaner.

- Removes heavy oils, greases, lubricants, buffing and lapping compounds, fingerprints, contaminants, silicone oils, and ink markings
- Safe on aluminum, brass, bronze, copper, steel, glass, plastics, hard rubber, and ceramics



MA 6024



MA 6036

CHEM-CREST® 77G RINSE SOLUTION & CORROSION INHIBITOR

A rust inhibitor concentrate provides short-term oxidation protection during rinsing and air-drying applications.

- Only use with rinse cycle in rinse tank
- Ideal for cleaning tooling prior to long-term storage
- **For use on steels only**
- Do not use on aluminum, copper-, or zinc-containing substrates

ULTRASONIC CLEANING SOLUTIONS

Part No.	Item Description
MA 6026	Natoli Alkaline Wash Solution
MA 6023	Chem-Crest® 25 General Purpose Cleaning Additive
MA 6024	Chem-Crest® 211 Multipurpose Cleaning Additive
MA 6036	Chem-Crest® 77G Rinse Solution & Corrosion Inhibitor

MANUAL WASH SOLUTIONS

FM KRYSTALL FOOD-GRADE CLEANER

A non-viscous penetrating cleaner and lubricant specially developed for machinery used in the food and beverage processing and packaging industry where there is potential for incidental food contact.

FEATURES:

- Easily penetrate hard-to-reach places
- Protect against corrosion
- **NSF H1 registered**
- **Kosher and Halal certified**

FM KRYSTALL FOOD-GRADE CLEANER	
Part No.	Item Description
MA 6046	FM Krystall-5 gal. (18.93 L)

PK2 CLEANER

One-step cleaner and lubricant to help prevent rust and corrosion. Ideal for tooling, turrets, sockets, cam tracks, compression rolls, and scrapers, as well as providing protection against rust when storing parts.

- Specially formulated for use on tablet presses, capsule machines and other equipment
- Cleans and lubricates in one step without water
- Leaves an ultra-thin, highly protective film that guards against rust and corrosion
- Reduces downtime between batches

PK2 CLEANER	
Part No.	Item Description
MA 6232	PK2 Cleaner-1 gal. (3.8 L)

HEAVY-DUTY CITRUS DEGREASER

An orange-scented, concentrated citrus degreaser with increased cleaning performance capable of removing the most stubborn stains and spills.

- Recommended for ALL applications **below the compression zone**
- FDA-approved for non-food contact surfaces
- Biodegradable and environmentally safe
- Designed for international shipment

HEAVY-DUTY CITRUS DEGREASER	
Part No.	Item Description
SU 2536	Heavy-Duty Citrus Degreaser-1 gal. (3.8 L)



FOOD-GRADE DEGREASER

Remove grease with ease using fast evaporating, VOC-free degreaser.

- Ideal for use on punch heads and cam tracks



FOOD-GRADE DEGREASER	
Part No.	Item Description
SU 2543	Food-Grade Degreaser, Fast Evap. (1 pint)

AEROSOL CAN CLEANING AGENTS

CITRUS DEGREASER Green Choice

A multipurpose, orange-scented, concentrated citrus degreaser capable of removing the most stubborn stains and spills.

- Recommended for ALL applications **below the compression zone**
- USDA approved for non-food contact surfaces
- Biodegradable and environmentally safe
- Great alternative to petroleum solvents



SU 2535 MA 6137

STAINLESS STEEL DRY CLEANER

Formulated to clean, restore, and preserve stainless steel.

- Retards tarnishing, corrosion, bacteria and water stains
- Prevents discoloration, dirt accretion, streaks and finger prints
- Contains no acids, alkali or abrasives
- **NSF K1 listed for use in food industry**

AEROSOL CAN CLEANING AGENTS	
Part No.	Item Description
SU 2535	Citrus Degreaser-16 oz. (454 g)
MA 6137	SS Dry-Cleaner-16.9 oz. (479 g)

ACETAL WASH BASIN

Keep tooling safe and secure with this durable and stable acetal wash basin during manual cleaning. This exclusive wash basin for tooling constructed of tough thermoplastic is highly resistant to solvents and chemicals. It has a low moisture sensitivity, fits any size tooling, and features 15 deep channels to secure tooling in place.

EXTERIOR DIMENSIONS (L X W):

- **Exterior Dimensions:** 24³/₈ x 10" (619 x 254mm)
- **Interior Dimension:** 23³/₈ x 9" (593.72 x 228.6 mm)



ACETAL WASH BASIN	
Part No.	Item Description
MA 6250	Acetal Wash Basin



6" LINEN PHENOLIC EMBOSSING PICKS

Lint-free picks remove stubborn product from hard-to-reach places.

FEATURES:

- Non-scratch material, perfect for punch faces



MA 7515 in use

6" LINEN PHENOLIC EMBOSSING PICKS



Part No.	Item Description
MA 7515	6" Linen Phenolic Embossing Picks

SOFT-TIP NYLON BRUSH

Acetal handle and nylon bristles are great for safely and easily removing product from punch cups. Ideal for tooling maintenance and preservation.



SOFT-TIP NYLON BRUSH

Part No.	Item Description
SU 0500	Soft-Tip Nylon Brush

DIE BORE CLEANING BRUSHES

Cleans die bore to prevent lower punch tips from binding in the die.



DIE BORE CLEANING BRUSHES

Part No.	Brush Diameter
SU 0107	1/4" (6.35 mm)
SU 0108	3/8" (9.52 mm)
SU 0109	1/2" (12.7 mm)
SU 0110	5/8" (15.87 mm)
SU 0111	3/4" (19.05 mm)
SU 0112	7/8" (22.22 mm)
SU 0113	1" (25.4 mm)

EXCLUSIVE TURRET GUIDE CLEANING BRUSHES

Heat and abrasion resistant, Natoli's line of custom, pharmaceutical-grade brushes feature high-density, ultra-stiff 612 nylon bristles. **These brushes are exclusively available through Natoli.**

ULTRA-STIFF NYLON BRISTLE BRUSHES

Excellent for proper punch guide cleaning.

- 12" (304.8 mm) spiral tube brush (with loop end)



ULTRA-STIFF NYLON BRISTLE BRUSHES



Part No.	Brush Diameter	Punch Type
SU 0058	3/4" (19.05 mm)	B
SU 0060	1" (25.4 mm)	D
SU 0062	1 1/8" (28.575 mm)	533/328-45
SU 0064	1 1/4" (31.75 mm)	533/328-33 or DS3
SU 0066	1 5/16" (33.33 mm)	DD2-31

DIE POCKET SIDE-ACTION CLEANING BRUSHES

Use to clean die pockets to ensure accurate die seating.

- 12" (304.8 mm) spiral tube brush (no loop)



DIE POCKET SIDE-ACTION CLEANING BRUSHES

Part No.	Brush Diameter	Punch Type
SU 0100	0.945" (24 mm)	BB
SU 0101	1.187" (30.14 mm)	B
SU 0103	1.500" (38.1 mm)	D
SU 0102	1.312" (33.32 mm)	533/328-45
SU 0104	1.625" (41.275 mm)	533/328-33
SU 0105	2.000" (50.8 mm)	DS3
SU 0106	2.125" (53.975 mm)	DD2 or DDS2

STEEL BRUSH HOLDER

- Use in pneumatic or electric drill chucks (see page 20)
- 3 3/8 x 1/4" (85.72 x 6.5 mm)



STEEL BRUSH HOLDER

Part No.	Item Description
SU 0121*	Reusable Brush Holder

*Brush not included

LINT-FREE WIPING CLOTHS

Solvent-resistant, multipurpose, heavy-duty cleaning cloths.

- Quickly absorb liquids, oils and greases



LINT-FREE WIPING CLOTHS

Part No.	Item Description
MA 6018	Lint-Free Wiping Cloths (140 Count)

PROTECTANT FACEMASK

With a clear polycarbonate face shield, receive full-face protection even in the most demanding work environments. The turn-lock knob conveniently tightens/loosens the headgear while being worn to provide maximum comfort and safety.



PROTECTANT FACEMASK

Part No.	Item Description
MA 9010	Protectant Facemask

16 OZ. SPRAY BOTTLE

Nozzle adjusts from mist to steady stream and helps provide a more accurate flow control. **Perfect for use with H-1 Tooling Storage Protectant (see page 84) and/or PK2 (see page 44).**



SPRAY BOTTLE

Part No.	Item Description
MA 3000	16 oz. Spray Bottle (2/Pack)

130–930 °F (54–499 °C) HEAT GUN

This 120v/1200w heat gun provides a temperature range of 130–930°F (54–499°C). The push-button variable temperature control and two-speed motor make this heat gun ideal for fast and efficient tool drying.



HEAT GUN

Part No.	Item Description
MA 9000	130–930 °F (54–499 °C) Heat Gun

Photograph representation only. Actual product may vary from image.

INSPECTION

Tablet production is stressful on punches and dies. Extending tool life saves operating costs and produces high-quality tablets. Consistent tool inspection procedures help you know when your tools are worn. The **Horizontal Optical Comparator** provides a bright, crisp visual for error-free inspection of compression tooling and tablets. Using the correct inspection equipment is an important step to increase tablet quality and reduce tooling costs.

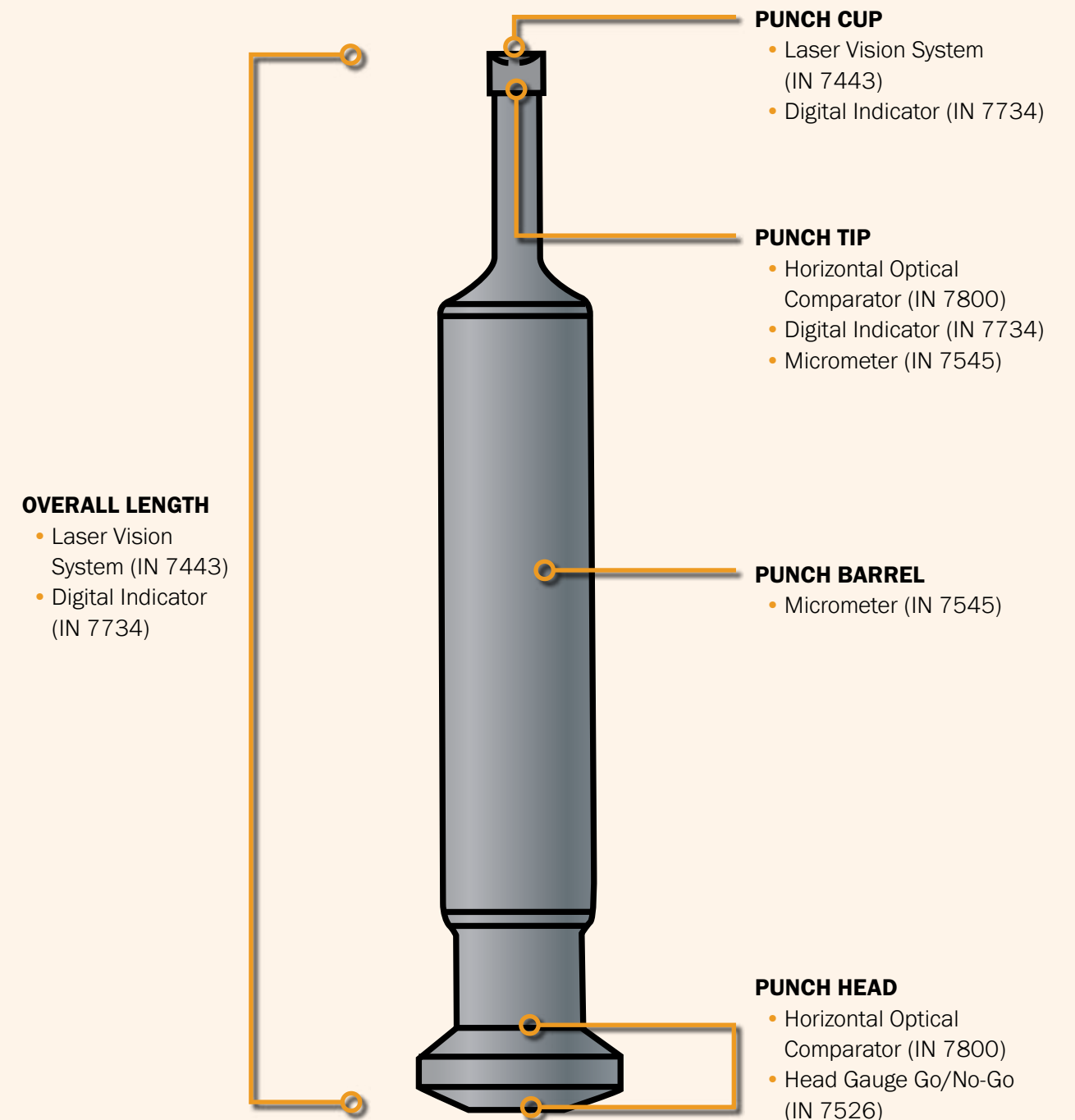

HORIZONTAL OPTICAL COMPARATOR

The **ONLY** method for checking punch tip wear and perfect for inspecting surface details of engraving, embossed logos, bisects, and punch head profiles, the Horizontal Optical Comparator is the most versatile piece of inspection equipment. It provides a bright, crisp image for error-free inspection of tooling AND tablets.

INSPECTION WITH THE HORIZONTAL OPTICAL COMPARATOR:

1. Measure punch tip wear
2. Using overlays, compare tablet embossing with original tablet drawing to ensure accuracy
3. Check tablet contour, i.e., cup radius (with overlays)
4. Check head configuration



A MUST for checking tip wear



Check tablet profile and flashing

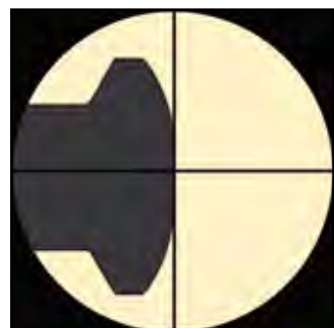

Check head configuration



Contact us about customized Mylar® overlays!

HORIZONTAL OPTICAL COMPARATOR

Part No.	Item Description
IN 7800	Horizontal Optical Comparator
IN 7801	Machine Stand
IN 7803	KA Counter

MUST HAVE!

Shown with IN 7801 and IN 7803

FEATURES:

- Generous X, Y work stage travel— 8 x 4" (203.2 x 101.6 mm)
- Handles workloads up to 100 lb. (45 kg)
- 10x projection lens
- Fiber illuminator included
- KA Counter displays measurements and dimensions of tooling (optional)
- Machine stand features lockable compartment to hold overlays and accessories (optional)

EXTERIOR DIMENSIONS (L X W X H):

- 53.3 x 25.5 x 43.3" (1.355 x 0.648 x 1.10 m)

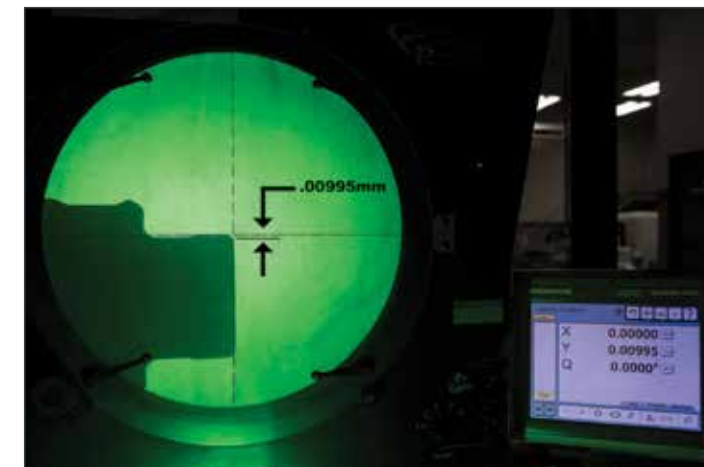

With a comparator, the magnified silhouette of a punch tip is projected upon a screen, usually at 10x, but can also be at 20x or even greater magnification. The wear of the part can be easily inspected and even measured against prescribed limits.

CUSTOMIZED OVERLAYS FOR THE HORIZONTAL OPTICAL COMPARATOR

Easily confirm conformants of your punch cup to drawing with customized overlays for the Horizontal Optical Comparator. By checking embossing of punch cups for deviation from tablet drawings, you'll also have better security against counterfeit tablets.

Discovering your tablet does not match the tool drawing is a common problem. When reordering tooling, if your tablet is out of specification from the drawing, the decision will need to be made if your tool will match the drawing or a produced tablet.

HOW CUSTOMIZED OVERLAYS WORK:

1. Punch tip to be inspected
2. A clear overlay is created from a tablet drawing
3. Customized overlay is placed on the screen
4. Easy adjustments are made to align overlay with punch tip

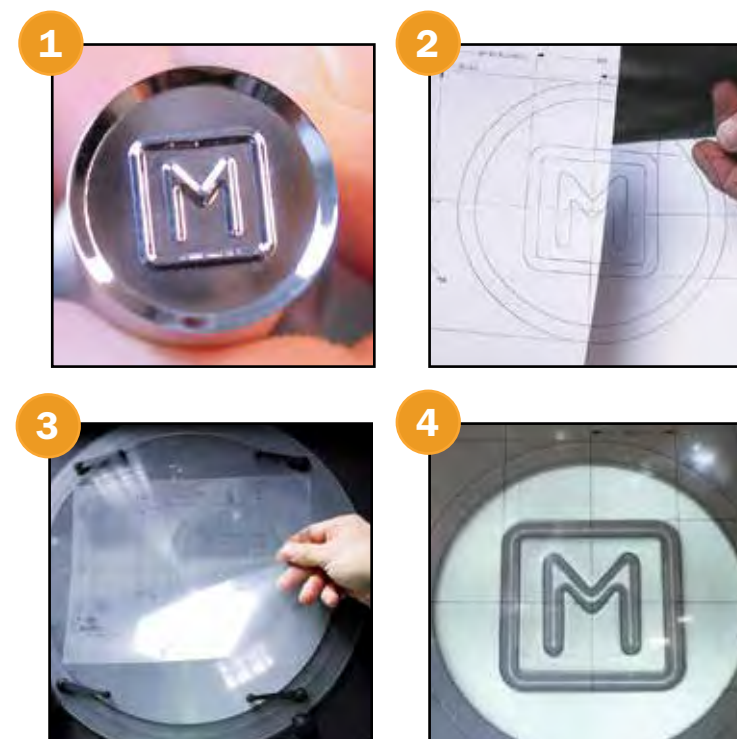

LASER VISION PUNCH INSPECTION SYSTEM (LVS)

Speed up the inspection process with this non-contact laser punch inspection system. Laser technology measures the critical dimensions of a punch: working length, cup depth, and overall length for precise, automated inspections in seconds.

FEATURES:

- Multi-tip tooling capability
- Efficient one-step measurements
- Enhanced camera view of punch cup with zoom lens
- More control with enhanced software interface
- Automatic real-time measurements
- Integrated touchscreen controls
- Image capture function
- All electrical, few moving parts



New streamlined design features an upgraded software system and smaller footprint.

LASER VISION PUNCH INSPECTION SYSTEM

Part No.	Item Description
IN 7443	LVS Automatic Laser Punch Inspection System
LE 7051	LVS Equipment Cover (not shown)
IN 7449	"B" Tooling Nest
IN 7445	"B" Tooling Reference Point Length Standard (not shown)
IN 7446	"B" Tooling Reference Standards (not shown)
IN 7448	"D" Tooling Nest (not shown)
IN 7444	"D" Tooling Reference Point Length Standard (not shown)
IN 7447	"D" Tooling Reference Standards (not shown)
IN 7440	Natoli "FS12 Type" Short Reference Standard (not shown)
IN 7441	Natoli "FS12 Type" Long Reference Standard (not shown)

MUST HAVE!



Laser Vision System (LVS) laser focused on punch cup and displayed in real time on monitor

The "non-contact" LVS system utilizes dual laser technology to inspect punches. Unlike the sharp point on a gauge, a laser beam poses no risk of scratching the surface of the punch tip when trying to locate the deepest point of the cup. And with no moving parts, the LVS is virtually maintenance-free.



Laser Vision System infrared laser focused on a multi-tip punch



Detect tip damage with the Laser Vision System's camera

The LVS interfaces with Tool Management II (TM-II) database software (see page 54) for automatic inspection data storage and analysis, making it the most powerful punch inspection and tool control device available. Measurements are transferred directly into the database with the click of a button, increasing efficiency and eliminating data entry errors. The automated "no-nonsense" approach eliminates the need for traditional time-consuming, inaccurate, and costly inspection procedures and prevents press downtime by inspecting and automatically recording the critical dimensions.

Proper analysis of the punch working length dimension is a critical function of the TM-II application. As such, the working length measurement of each punch is compared to the working lengths of the other punches rather than to preset tolerance values. Learn more about TM-II software and compatible inspection kits on pages 54-55.



NATOLI'S TOOL MANAGEMENT II (TM-II) SOFTWARE PACKAGE

Forecast tooling life to eliminate defective tablets! Keep records of critical working lengths and easily manage your inventory including tool matching, storage, usage, location, inspection and tolerance reporting. Natoli's Tool Management II (TM-II) software is the most powerful and comprehensive tooling database available and helps tablet manufacturers improve product quality and consistency, eliminates waste, and ensures compliance with cGMP record-keeping requirements.

TM-II places comprehensive tool management and inspection information at your fingertips, resulting in better tablet quality and reduced press downtime, creating a scenario where there is virtually no deviation in tablet overall thickness. The software can be used with various digital electronic measuring devices such as the LVS (IN 7443—see pages 52–53) and digital indicator (IN 7508—see page 56).

MANAGE TOOLING INVENTORY THROUGH:

- Tool matching
- Tool storage
- Tool inspection
- Tolerance reporting
- Monitoring tool usage
- Identifying tool location
- Maintaining tool drawing files
- Printing reports
- Creating purchase orders for additional or replacement tool sets
- 21 CFR Part 11 Compliant

AND MORE!

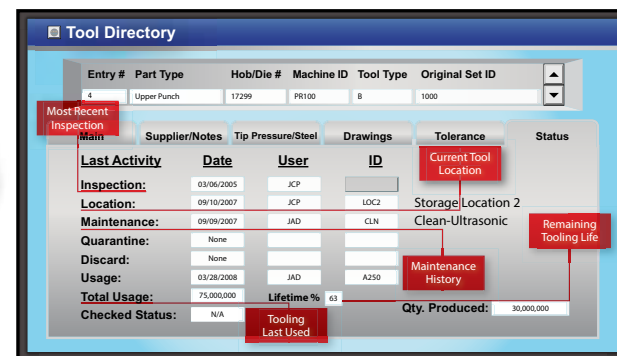
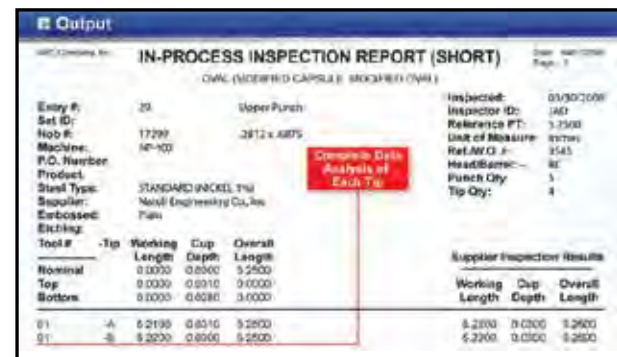
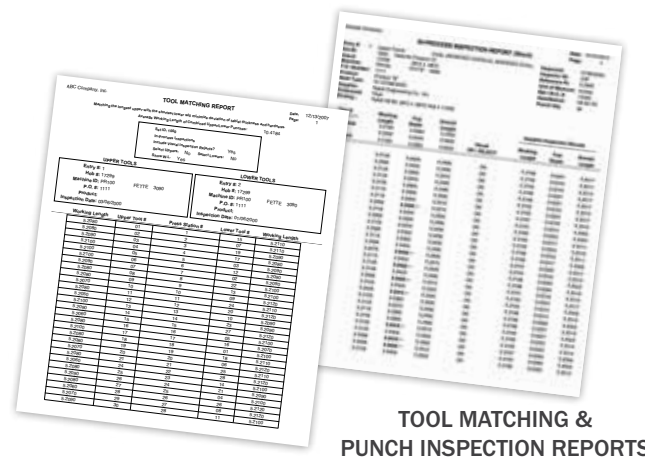
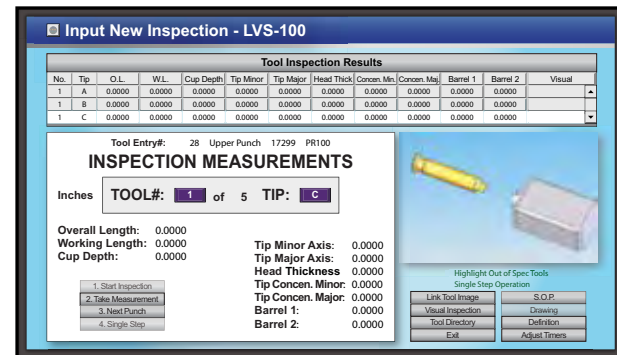
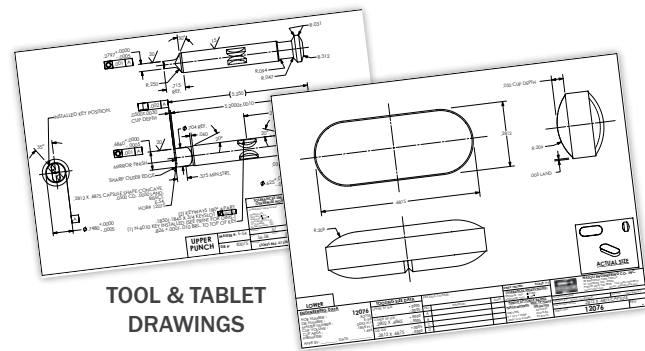

TOOL MANAGEMENT II (TM-II) SOFTWARE

Part No.	Item Description
IN 7578	TM-II Software (Single-User)
IN 7579	TM-II Multi-User Network Upgrade (5-User)
IN 7599	TM-II Multi-Tip Module (Software Add-on)
IN 7560	TM-II Software Validation Package

MUST HAVE!

TM-II SOFTWARE COMPATIBLE INSPECTION KITS

Eliminate manual record-keeping! Manually measure tooling with any kit in conjunction with the TM-II software by storing measurements quickly and error-free. Data will transfer directly from measurement device to computer. Kits also include a foot controller, data input tool for USB port, and a connecting cable (not shown). **All items are available for purchase separately.**

WORKING LENGTH, CUP DEPTH & OVERALL LENGTH KIT

- A. Digital indicator
- B. Granite gauge stand—6 x 6 x 2" (152.4 x 152.4 x 50.8 mm)
- C. Indicator lifting lever
- D. Indicator tip—long
- E. 5.25" (133.35 mm) height standard gauge
- F. Punch holder for "B" and "D" tooling



DIE ID, OD & OL KIT

- 0–1" (0–25.4 mm) digital micrometer
- 1–2" (25.4–50.8 mm) digital micrometer (not shown)
- 6" (152.4 mm) digital caliper

TIP & BARREL KIT FOR "B" & "D" TOOLING

- 0–1" (0–25.4 mm) digital micrometer

TIP & BARREL KIT FOR 533/328 TOOLING

- 1–2" (25.4–50.8 mm) digital micrometer (not shown)

TIP CONCENTRICITY KIT

- Digital indicator
- Granite gauge stand—6 x 6 x 2" (152.4 x 152.4 x 50.8 mm)
- Indicator lifting lever
- Indicator tip—long
- 5" (127 mm) V-block with head and key cutout and clamp



5" V-block with head and key cutout (clamp not shown)

TOOL MANAGEMENT II (TM-II) COMPATIBLE KITS

Part No.	Item Description
IN 7583	Working Length, Cup Depth and OL Kit
IN 7718	Die ID, OD and OL Kit
IN 7715	Tip and Barrel Kit for "B" and "D" Tooling
IN 7716	Tip and Barrel Kit for 533/328 Tooling
IN 7717	Tip Concentricity Kit

MANUAL PUNCH INSPECTION

Check punch working length, overall length and cup depth for optimal tablet uniformity with Natoli's extensive line of necessary inspection items. Indicators can also be used for checking die table "run-out" and proper setting of feed frames, which reduces granulation loss and press damage.

DIAL INDICATOR

Easily check tip concentricity as the Dial Indicator with Indicator Base magnetizes to the V-Block Plate, while the V-block securely holds the punch in plate. Afix the Indicator Magnetic Base to tablet press to measure pressure rollers for run-out.

DIAL INDICATOR INSPECTION

Part No.	Item Description
IN 7504	Dial Indicator (Inch)
IN 7474	Dial Indicator (Metric)
IN 7501	Indicator Magnetic Base
IN 7565	V-Block with Head and Key Cutout
IN 7915	V-Block Plate with Nest



DIGITAL INDICATOR WITH ABSOLUTE ENCODER

Check the overall length, working length and cup depth of a punch to ensure proper tablet hardness, thickness and weight consistency. The indicator can also be used to check die table run-out for proper feeder installation.

FEATURES:

- Inch/mm conversion
- SPC port
- Always displays "absolute position" from origin at power-on
- Initial zero-setting repeated over battery life
- Upper and lower tolerance limit setting
- Go/no-go judgment

DIGITAL INDICATOR INSPECTION

Part No.	Item Description
IN 7508	Digital Indicator with SPC Readout
IN 7588	Indicator Lifting Lever
IN 7503	Granite Gauge Stand & Extension Pole—6 x 6 x 2" (152.4 x 152.4 x 50.8 mm)
IN 7575	Punch Holder "B" Type
IN 7577	Punch Holder "D" Type (not shown)
IN 7546	Digimatic Mini-Processor/Printer

MUST HAVE!



WIGAUGE DIGITAL TESTER

Test dies and die table segments with increased efficiency in any environment using this digital die bore test gauge. The WiGauge eliminates cumbersome cables by wirelessly transmitting collected measurements into a spreadsheet using Bluetooth technology. **Measures die wear ring only.**

FEATURES:

- Calibrated, rugged handle for quick measurement checks
- Software allows for logging of measurements to CSV/Excel files
- LCD screen that shows a live reading, as well as min/max
- Class 1 Bluetooth antenna for easy data transmission up to 50 ft (15 meters)
- Chargeable/replaceable battery pack with up to 10-hour life

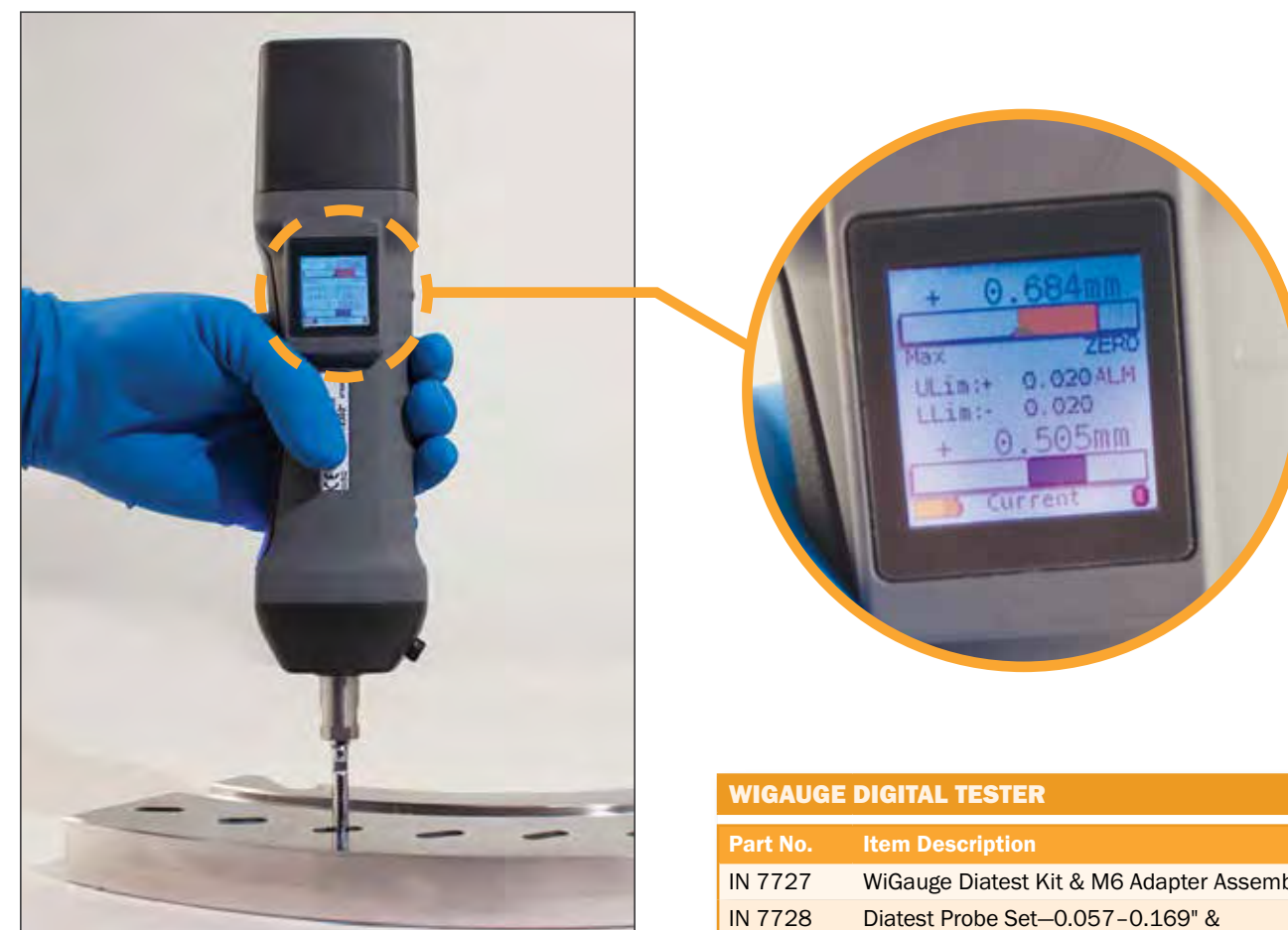

WIGAUGE DIGITAL TESTER

Part No.	Item Description
IN 7727	WiGauge Diatest Kit & M6 Adapter Assembly
IN 7728	Diatest Probe Set—0.057–0.169" & Master Ring Set 1.448–4.293 mm
IN 7729	WiGauge Diatest Kit with 0.165–0.394" & Master Ring Set 4.191–10 mm

DIE BORE GAUGE TEST STAND

Measuring die wear ring does **NOT** have to be a difficult procedure. Natoli has both manual and digital solutions. Worn dies may reduce punch life by as much as 50%. Die wear rings cause premature tool wear and punch binding, causing tablet defects such as capping, lamination, discoloration (black specks), and more. *Natoli does not advise to operate a tablet press combining new punches and worn dies (or vice versa).* Each Die Bore Gauge Test Stand includes a digital indicator, stand, and one split ball bore gauge set.



Split Ball Probe Set will be based off die bore dimensions (tablet size).



DIE BORE GAUGE TEST STAND

Part No.	Item Description
IN 7721	Die Bore Gauge Stand
IN 7734	Digital Indicator (Std/Imp)
IN 7736	Digital Indicator Metric

MUST HAVE!

SPLIT BALL BORE GAUGE (PROBE SET) WITH SETTING RINGS

Part No.	Range
IN 7740	0.037-0.061"
IN 7741	0.060-0.157"
IN 7722	0.145-0.290"
IN 7744	0.95-1.55 mm
IN 7745	1.5-4.0 mm
IN 7746	3.7-7.3 mm

SPLIT BALL BORE GAUGE (PROBE SET) WITHOUT SETTING RINGS

Part No.	Range
IN 7742	0.3-0.4"
IN 7743	0.4-0.7"
IN 7747	7-10 mm
IN 7748	10-18 mm



Die Wear Ring



Split Bore Gauge



Split Bore Gauge in Die



Split Bore Gauge in Die

DELUXE DIGITAL HANDHELD MICROSCOPE

View punch tip damage in spectacular detail with this small, handheld Deluxe Digital Microscope. **CE compliant.**

FEATURES:

- 10x-50x, 240x variable magnification
- 5 mega-pixels
- 2584 x 1936 resolution
- Built-in polarizer for glare reduction
- 8 white built-in LEDs (on/off)
- Built-in measurement feature with calibration
- Micro-touch trigger for quick photos/videos
- Metal aluminum alloy encasement
- USB powered



Punch Tip Damage Photo Taken with IN 7951



Punch Tip Damage Photo Taken with IN 7951

DIMENSIONS (H X D):

- 4 x 1.26" (102 x 32 mm)



*Shown with item IN 7965



DELUXE DIGITAL HANDHELD MICROSCOPE AND ACCESSORIES

Part No.	Item Description
IN 7951	Deluxe Digital Handheld Microscope Kit (Includes IN 7960, IN 7963, IN 7966, IN 7961, IN 7965, IN 7964, and IN 7967)
IN 7960	Tabletop Stand
IN 7963	Dual USB Foot Pedal Trigger (not shown)
IN 7966	Removable Diffuser Kit for IN 7951
IN 7961	Pole Extension for IN 7960
IN 7965	Flexible Arm for IN 7960
IN 7964	XY Rotating Base (not shown)
IN 7967	Polarized LED Light (USB Powered)

HANDHELD DIGITAL MICROSCOPE

View small blemishes in tablets, punches and dies at up to 500x magnification on the built-in, flip-out screen. Save magnified images and video for later review on a micro-SD card. The unit comes with a micro-USB cable for downloading images and recharging.

FEATURES:

- 20x–200x optical magnification, 500x digital magnification*
- 5 mega-pixels
- 2592 x 1944 resolution
- 3" TFT color LCD screen with 960 x 240 pixel resolution
- AVI video stored at 640 x 480 resolution
- Save images on micro-SD card up to 32 GB (not included)
- Compatible with Windows 10/8/7/Vista/XP
- Eight white built-in LEDs
- Micro-USB cable for downloading images and recharging
- Full charge provides up to four hours of operation

DIMENSIONS (H X D):

- 5 x 4.5 x 1" (127 x 114.3 x 25.4 mm)



3" color LCD screen provides instant viewing



Compact design allows for on-the-go inspection and eight bright white LEDs help illuminate objects.

HANDHELD DIGITAL MICROSCOPE

Part No.	Item Description
IN 7975	Handheld Microscope with LCD Screen

MUST HAVE!

*Zoom function not available while USB tethered.

3-STEP VALIDATION HEIGHT STANDARD GAUGES

Validate digital indicator accuracy with Natoli calibration standards. **Custom manufactured height standards are available upon request.**

- A **Certificate of Calibration** is included with each standard
- For use with validation of dial indicator

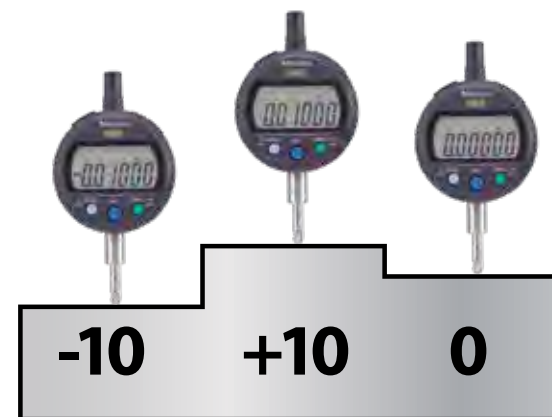

3-STEP VALIDATION HEIGHT STANDARD GAUGE

Part No.	Item Description
IN 7597	5.25" 3-Step (±0.01)
IN 7649	5.26" 3-Step (±0.01)

HEIGHT STANDARD GAUGE

Set up inspection gauge to the most common tool lengths. **Custom sizes available upon request.**



HEIGHT STANDARD GAUGE

Part No.	Item Description
IN 7589	5.25" (133.35 mm)
IN 7648	5.26" (133.6 mm)
IN 7000	6.062" (154 mm)
IN 7001	6.250" (159 mm)

MUST HAVE!

MINI-PROCESSOR/PRINTER & SPC CONNECTING CABLES

Transfer data from inspection equipment to printer or computer. The mini-processor can be used with TM-II (see page 54) and features a built-in thermal line printer. SPC Connecting Cable purchased separately.

FEATURES:

- Records measurement data
- Tolerance judgment
- Statistical analysis and history
- Records calculation results



MINI-PROCESSOR/PRINTER & SPC CONNECTING CABLES

Part No.	Item Description
IN 7546	Digimatic Mini-Processor
IN 7550	10-Pack Thermo Paper Rolls
IN 7572	220v Adapter
IN 7460	SPC Connecting Cable—40" (1.01 m) length, straight plug type
IN 7461	SPC Connecting Cable—80" (2.03 m) length, straight plug type

DIGITAL INDICATOR WITH ABSOLUTE ENCODER

Check the overall length, working length and cup depth to ensure proper tablet hardness, thickness and weight consistency. The indicator can also be used to check die table run-out for proper feeder installation.

FEATURES:

- Inch/mm conversion
- SPC port
- Always displays "absolute position" from origin at power-on
- Initial zero-setting repeated over battery life
- Upper and lower tolerance limit setting
- Go/no-go judgment
- Use with IN 7461 cable (see page 61)



MUST HAVE!

DIGITAL INDICATOR WITH ABSOLUTE ENCODER

Part No.	Measuring Range	Accuracy
IN 7734	0-0.5" (0-12.7 mm)	± 0.00012" (0.0030 mm)

DIAL INDICATOR

Easily check tip concentricity and die table run-out with the Dial Indicator. Use with Indicator Magnetic Base to secure to metal items.



DIAL INDICATOR

Part No.	Item Description
IN 7504	Dial Indicator (Inch)
IN 7474	Dial Indicator (Metric)
IN 7501	Indicator Magnetic Base

DIAL INDICATOR REPLACEMENT POINTS

Eliminates scratching of punch cups.

DIAL INDICATOR REPLACEMENT POINTS

Part No.	Item Description
IN 7507	Nylon Indicator Replacement Tip
IN 7513	Long Indicator Tip
IN 7506	22-Piece Set (9 Flat, 5 Ball, 4 Tapered, 3 Regular, 1 Bent-Regular)



DIGITAL CALIPERS WITH ABSOLUTE ENCODER

Designed for both outside and inside die diameter measurements, calipers feature an Absolute Encoder with special functions that allow it to remember its measuring position after being switched off.

ABSOLUTE ENCODER FEATURES:

- **Origin:** Allows setting of an origin point to be used for reference in subsequent measurements. Once set, the Absolute Encoder caliper will switch on, showing its true position from the origin point rather than from 0.0000 as with standard models.
- **Zero/ABS:** Allows the display to be set to zero at any point along the slider for incremental comparison measurements. This switch will also allow return to the absolute mode and display the true position from the origin point.

CALIPER FEATURES:

- Inch/mm conversion
- SPC port
- Storage case included



DIGITAL CALIPERS WITH ABSOLUTE ENCODER

Part No.	Measuring Range	Accuracy
IN 7519	0-6" (0-152 mm)	± 0.001" (± 0.025 mm)
IN 7520	0-12" (0-300 mm)	± 0.0015" (± 0.038 mm)

TABLET THICKNESS GAUGES

Quickly and accurately check overall tablet thickness.

- Includes a Certificate of Conformance
- May be purchased with a Certificate of Calibration (see page 70).

HANDHELD DIGITAL TABLET THICKNESS GAUGE

- Zero/ABS
- Inch/mm conversion
- SPC port
- Use with IN 7460 connecting cable (see page 61)

MUST HAVE!



HANDHELD DIGITAL TABLET THICKNESS GAUGE

Part No.	Measuring Range	Accuracy	Throat
IN 7522	0-0.47" (0-11.93 mm)	± 0.001" (± 0.015 mm)	1.18" (29.97 mm)

POCKET DIGITAL QUICK MINI GAUGE

- Zero/ABS
- Inch/mm conversion
- Low battery alarm



POCKET DIGITAL QUICK MINI GAUGE

Part No.	Measuring Range	Accuracy	Throat
IN 7502	0-0.5" (0-12 mm)	± 0.001" (± 0.02 mm)	0.91" (23.11 mm)

OUTSIDE MICROMETERS

Measure punch diameters, tip dimensions, and tablet thickness with outside micrometers. A Certificate of Inspection is included with each Mitutoyo instrument listed in this section.

Selecting the Proper Micrometer Measuring Range:

- A measuring range of 0–1" (0–25.4 mm) is used for "B" and "D" punch barrels and tips and 0.945" (24 mm) dies
- A measuring range of 1–2" (25.4–50.8 mm) is used for punch barrels and tips larger than 1" and die diameters of 1.1875" (30.1625 mm) and 1.5" (38.1 mm)

DIGITAL MICROMETERS WITH ABSOLUTE ENCODER

- SPC port
- Carbide-tipped measuring face
- Inch/mm conversion
- Storage case included

MUST HAVE!



DIGITAL MICROMETERS WITH ABSOLUTE ENCODER

Part No.	Measuring Range	Accuracy	Standard
IN 7425	0–1" (0–25.4 mm)	±0.00005" (±0.00127 mm)	—
IN 7426	1–2" (25.4–50.8 mm)	±0.00005" (±0.00127 mm)	1" (25.4 mm)

IN 7425 measures BB dies, and B and D punches. IN 7426 measures B and D dies. Use with IN 7460 cable (see page 61).

DIAL MICROMETERS

- Carbide-tipped measuring face
- Storage case included



DIAL MICROMETERS

Part No.	Measuring Range	Accuracy	Standard
IN 7512	0–1" (0–25.4 mm)	±0.0001" (±0.00254 mm)	—
IN 7514	1–2" (25.4–50.8 mm)	±0.0001" (±0.00254 mm)	1" (25.4 mm)

IN 7512 measures BB dies, and B and D punches. IN 7514 measures B and D dies.

MICROMETER STANDS

Take clumsiness out of your measurements. When you need two hands, the micrometer stand is a must!

- Weighted base
- 6.5 x 4.5 x 3.5" (165 x 114 x 89 mm)

MICROMETER STANDS

Part No.	Item Description
IN 7498	Fixed-Angle Micrometer Stand
IN 7499	Swivel-Angle Micrometer Stand



WISE WITH VACUUM BASE & JAW PROTECTORS

Designed to secure a variety of work pieces. **Great for safely removing and replacing keys.**

- 360° rotation, 360° swivel, 90° pivot
- Includes replacement set of rubberized jaws
- **Adjustable jaws:** 0–2.5" (0–63.5 mm)



WISE WITH VACUUM BASE & JAW PROTECTORS

Part No.	Item Description
IN 7562	Vise with Vacuum Base

V-BLOCK AND V-BLOCK PLATE WITH NEST

Check punch and die concentricity easily as the Dial Indicator with Indicator Base (see page 62) magnetizes to the V-Block Plate, while the V-Block securely holds the punch in place.



MUST HAVE!

V-BLOCK AND V-BLOCK PLATE WITH NEST

Part No.	Item Description
IN 7565	V-Block with Head and Key Cutout
IN 7915	V-Block Plate with Nest

MULTI-TIP/ROTATING HEAD V-BLOCK KIT

Easily assemble and disassemble multi-tip or rotating head tooling. V-Block is custom manufactured with head cutout and pin drive opening for easy retrieval.

FEATURES:

- V-block with head and key cutout and pin driving opening
- V-block plate with nest
- Punch hold-down clamp for V-block
- "B" punch securing block
- "D" punch securing block
- 328 punch securing block
- DS3 punch securing block



MULTI-TIP/ROTATING HEAD V-BLOCK

Part No.	Item Description
IN 7910	V-Block with Head and Key Cutout and Pin Driving Opening
IN 7915	V-Block Plate with Nest
IN 7920	Punch Hold-Down Clamp for V-Block

MULTI-TIP/ROTATING HEAD V-BLOCK

Part No.	Item Description
IN 7920-B	"B" Punch Securing Block
IN 7920-D	"D" Punch Securing Block
IN 7920-328	328 Punch Securing Block
IN 7920-DS3	DS3 Punch Securing Block

PUNCH KEY GAUGES

Ensure a proper fit between the punch key and turret guide keyway with Natoli Punch Key Gauges.

PUNCH KEY GAUGES				
Part No.	Punch Type	"A"	"B"	"C"
IN 7521	"B"	0.1875-0.1880" (4.76-4.77 mm)	0.7500" (19.05 mm)	0.834" (21.18 mm)
IN 7523	"D"	0.1875-0.1880" (4.76-4.77 mm)	1.0000" (25.4 mm)	1.084" (27.53 mm)
IN 7647	533/328-33	0.2500-0.2505" (6.35-6.36 mm)	1.2500" (31.75 mm)	1.3580" (34.49 mm)
IN 7646	533/328-45	0.1875-0.1880" (4.76-4.77 mm)	1.1250" (28.57 mm)	1.2040" (30.58 mm)

Certificate of Calibration available. See part IN 7400 (see page 70).

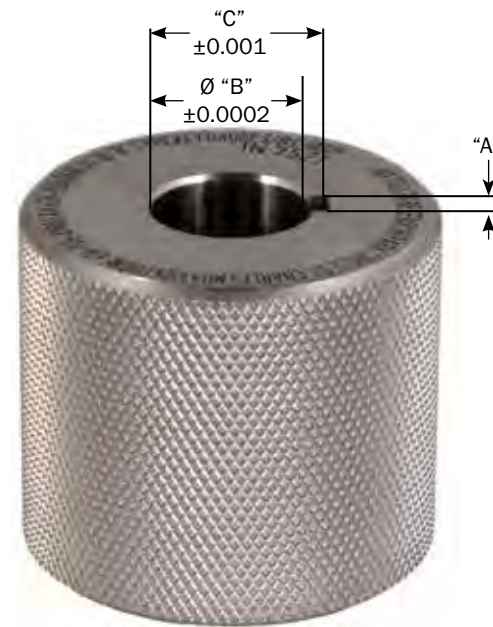

LOWER CALIBRATION PUNCHES

- Used to check punch tips at tablet take-off
- Low ejection can damage tablets.
- High ejection can damage tools, tablet take-off, feeder pans, etc.



LOWER CALIBRATION PUNCHES	
Part No.	Punch Type
SU 0234	B
SU 0235	D
SU 0236	B2
SU 0237	533/328-45
SU 0239	Tip Deflection Special Order
SU 0238	Special Order

Certificate of Calibration available. See part IN 7400 (see page 70).

DIE POCKET GAUGE

Is your die pocket experiencing premature wear or tip breakage? Die Pocket Gauges are sized to determine if die pocket is oversized or worn. *Custom die pocket gauges are available upon request.*



DIE POCKET GAUGE		
Part No.	Punch Type	Diameter
SU 0157	BB (0.945"/24 mm)	0.9455" (24.02 mm)
SU 0159	B (1.1875"/30.16 mm)	1.1880" (30.18 mm)
SU 0163	D (1.50"/38.1 mm)	1.5005" (38.11 mm)
SU 0153	D (1.50"/38.1 mm)	1.5010" (38.13 mm)

HEAD GAUGE GO/NO-GO

Accurately checks and confirms punch head and profile. *Custom head gauges are available upon request.*

HEAD GAUGE GO/NO-GO	
Part No.	Punch Type
IN 7526	TSM "B"
IN 7529	Domed—"B"
IN 7551	European (EU-19)—"B"
IN 7553	Kilian European—"B"
IN 7555	Korsch European—"B"
IN 7557	Manesty European—"B"
IN 7528	TSM "D"
IN 7530	Domed—"D"
IN 7552	European (EU-1)—"D"
IN 7556	Korsch European—"D"
IN 7558	Manesty European—"D"
IN 7527	533/328 45-Station Turret
IN 7535	Domed—533/328 45-Station Turret
IN 7672	533/328 33-Station Turret
IN 7673	Domed—533/328 33-Station Turret
IN 7525	DS3
IN 7534	Domed—DS3
IN 7559	Special Order



CERTIFIED TURRET INSPECTION KITS

Potentially avoid tablet capping and lamination by ensuring proper punch tip to die bore alignment. Each kit includes punch guide go/no-go gauge, alignment rods and corresponding die(s).

- Easy-to-use instructions included
- Certificate of Calibration included



CERTIFIED TURRET INSPECTION KITS	
Part No.	Punch Type
IN 7659	"B"
IN 7660	Fette "B" 19 mm or Kikusui "B" New Style
IN 7641	Courtroy "B"
IN 7677	Korsch "B"
IN 7622	Kikusui "B"—Old Style
IN 7846	Kilian "B"
IN 7658	"D"
IN 7661	Fette "D" 25.35 mm or Kikusui "D" New Style
IN 7678	Korsch "D"
IN 7666	Kikusui "D"—Old Style
IN 7859	Kilian "D"
IN 7664	533/328-45
IN 7668	533/328-33
IN 7662	DD2-23
IN 7663	DS3
IN 7674	Special Order

MUST HAVE!

TURRET KEYWAY INSPECTION GAUGES

Prevent damage to tooling by inspecting for proper keyway alignment and wear.

- Extends tool life by reducing tool damage
- Easy-to-use
- Economical solution

TURRET KEYWAY INSPECTION GAUGES

Part No.	Punch Type
IN 7612	"B" Tooling
IN 7642	Fette "B"
IN 7837	Kikusui "B" Old Style
IN 7839	Kikusui "B" New Style
IN 7851	Korsch "B"
IN 7880	Korsch EU "B"
IN 7638	Courtoy "B"
IN 7613	"D" Tooling
IN 7632	Fette "D"
IN 7836	Kikusui "D" Old Style
IN 7838	Kikusui "D" New Style
IN 7855	Korsch "D"
IN 7881	Korsch TSM-D
IN 7637	533/328-45
IN 7858	Stokes DS3
IN 7887	Kilian 20/28
IN 7686	Special Order

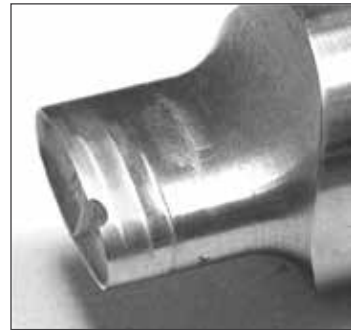

Damage to punch tip from improper alignment



Damage to key from excessive wear

Certificate of Calibration available.
See part IN 7400 (see page 70).

PUNCH HOLDING TRAYS

Provides safer handling and storage while reducing tooling damage.

- Prevents punches from rolling off work area
- Suitable for "B" and "D" tooling

SPECIFICATIONS:

- **MA 6025:** Holds seven punches
- **MA 6235 or MA 6236:** Holds 15 punches



MA 6235 or
MA 6236



MA 6025

PUNCH HOLDING TRAYS

Part No.	Item Description
MA 6025*	Punch Holding Strip (Yellow)
MA 6235	"B" Type Acetal Punch Holding Tray
MA 6236	"D" Type Acetal Punch Holding Tray

MUST HAVE!

*Interlocking ends for expandable capacity.

PUNCH HOLDERS

Stabilize punches when taking punch measurements.
Can be used with keyed or non-keyed punches.



PUNCH HOLDERS

Part No.	Tooling Size
IN 7575	"B" Tooling
IN 7577	"D" Tooling
IN 7574	533/328-33 Station Turret
IN 7576	533/328-45 Station Turret

LED MAGNIFIERS

Inspect tooling with illuminated magnifiers with surface-mounted LEDs with full dimming and quadrant contrast control. Multi-angle LEDs provide shadowless lighting and reduced glare, heat, and energy consumption.

FEATURES:

- 7 x 5.25" (177.8 x 133.35 mm) rectangular lens with 43" (1.09 m) arm
- 4-diopter (2x) lens
- 4x the lumen output of a standard magnifier
- IEC plug design allows for 100–240v use
- Each unit uses 8 watts max



LED MAGNIFIERS

Part No.	Base Style	Color
IN 7701	Clamp	Carbon Black
IN 7702	Clamp	Blaze Red
IN 7703	Weighted	Carbon Black
IN 7704	Weighted	Blaze Red

LIGHTING PHASES



Soft

Normal

Bright

Super Bright

PREMIUM LED HANDHELD MAGNIFIER

Great for spot checks and on-the-go, the 2" (50.8 mm) diameter lens is made of optical-grade, distortion-free glass with a magnification power of 2.5x for quick, handheld inspections. Illuminate object with installed high-power LEDs, powered by three (3) AA batteries.



FEATURES:

- Instant-on
- Flicker-free bulb
- Life of 50,000 hours
- Includes carrying case

PREMIUM LED HANDHELD MAGNIFIER

Part No.	Item Description
IN 7585	Premium Handheld Magnifier/12 White LEDs
IN 7586	Premium Handheld Magnifier/24 White LEDs

HANDHELD MAGNIFIERS AND EYE LOUPE

Use to inspect punch cups and tablets.



IN 7541



IN 7544

HANDHELD MAGNIFIERS AND EYE LOUPE

Part No.	Item Description	Focal Length
IN 7541	4x Illuminated Magnifier (Batteries and Bulb Included)	4" (101.6 mm)
IN 7544	4x Single Lens Eye Loupe	2.5" (63.5 mm)

NATOLI KEYCHAIN LIGHT

This high-powered keychain light is great for inspecting punch guides and the condition of key slots.



NATOLI KEYCHAIN LIGHT

Part No.	Item Description
IN 9000	Natoli Keychain Light

TABLETING SPECIFICATION MANUAL (CURRENT EDITION)

The Tableting Specification Manual (TSM) is the most valuable source of tooling information available.

SUMMARY OF TOPICS AND GUIDELINES:

- Tooling terminology and specifications
- Tablet design
- Tool steel, compression forces
- Procurement, inspection and maintenance
- Troubleshooting tablet production



TABLETING SPECIFICATION MANUAL

Part No.	Item Description
IN 7548	English
IN 7571	Spanish

MUST HAVE!

CERTIFICATE OF CALIBRATION

A Certificate of Calibration by Natoli is available for select instruments listed in this section.

- Annual calibration is recommended

CERTIFICATE OF CALIBRATION

Part No.	Item Description
IN 7400	Certificate of Calibration



MITUTOYO® CERTIFICATE OF INSPECTION

A Certificate of Inspection is included with each Mitutoyo instrument listed in the Inspection section. **Note: May special order with Certification of Calibration if needed.**

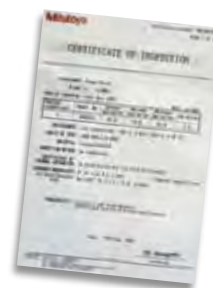

POLISHING

Properly polished tools provide consistent tablet quality and peak press performance all while maximizing tool life. The **Natoli Polishing Station** works great for solving tableting issues such as picking, sticking, capping and lamination, reducing J-hook and restoring the critical punch tip land. **Natoli's Automated Polishing Machine** allows unattended operation and provides a high-chrome finish to tooling.



Natoli 5-Head Automated Polishing Machine
Part No. MA 7300

Natoli Polishing Station
Part No. MA 5501

AUTOMATED POLISHING MACHINE

Efficiently remove product, abrasions, and harmful oxidation from tooling with Natoli's Automated Polishing Machine. After reworking punch tips with the Natoli Polishing Station's unsewn buffing wheel (see pages 74-75), simply load punches and media into the automated polishing machine, set cycle time, and push start. Fully immersed tooling is moved through polishing media in a circular motion, ensuring consistent polishing results every time. **Additional punch and die holders can be purchased separately.**

CAPACITIES:

- **5-Head:** 80 "B" or 60 "D" punches
- **6-Head:** 96 "B" or 72 "D" punches

FEATURES:

- One-year manufacturer's warranty
- Includes IQ/OQ documentation
- Includes training USB card
- 7" Siemens touchscreen
- Recipe/batch storage
- Punch/die holders feature quick-release system
- Punch holders available for most tooling sizes
- Interior LED lights
- Small footprint machine
- Stainless steel frame and bottom cover
- Batch management with printing option
- Octagonal process container, allowing optimal movement of the granulate during polishing process
- Stainless steel cover allows for easy cleaning of the polishing chamber
- Lower storage cabinet for media, additional holders, and compounds
- Stainless steel media mixing paddle
- Machine alerts user when new media is required
- Includes impregnation oil
- Includes dedusting nozzles at process container

OPTIONAL FEATURES:

- Die holders (see page 73)
- Media chilling option

EXTERIOR DIMENSIONS (L X W X H):

- **5-Head:** 42.30 x 34.56 x 77.24" (1.10 x 0.878 x 1.962 m)
- **6-Head:** 45.90 x 37.20 x 77.24" (1.166 x 0.945 x 1.962 m)

POWER:

- 230v, 50/60 Hz, 18 amps



AUTOMATED POLISHING MACHINE

Part No.	Item Description	Capacity
MA 7300	Natoli 5-Head Automated Polishing Machine	80 "B" or 60 "D" Punches
MA 7301	Natoli 6-Head Automated Polishing Machine	90 "B" or 72 "D" Punches
MA 7305	Media Chilling Option	—

ACCESSORIES FOR THE AUTOMATED POLISHING MACHINE

PUNCH HOLDERS

- Holds 16 "B" type punches
- Holds 12 "D" type punches
- Custom size available

DIE HOLDER

- Holds 16 dies
- Custom OD size available



AUTOMATED POLISHING MACHINE PUNCH HOLDERS

Part No.	Item Description
MA 7302	Punch Holder "B" Type
MA 7303	Punch Holder "D" Type
MA 7309	Special Order Punch Holder

AUTOMATED POLISHING MACHINE DIE HOLDERS

Part No.	Item Description
MA 7304	"BB" Die Holder
MA 7306	"B" Die Holder
MA 7304	"D" Die Holder
MA 7308	Special Order Die Holder

POLISHING MEDIAS FOR THE AUTOMATED POLISHING MACHINE

WALNUT POLISHING MEDIA

- Lasts approximately 225 cycle hours
- Infuse with polishing compound to help restore mirror-like finish to tooling
- Recommended for use with impregnation oil

PLASTIC POLISHING MEDIA

- Lasts approximately 225 cycle hours
- Calcium carbonate-free, minimizing residue
- Allergen-free
- Ideal for pharmaceutical use
- Recommended for use with impregnation oil

NATOLI POLISHING COMPOUND

Helps ensure uniform polishing results when used in conjunction with polishing media.

IMPREGNATION OIL

- Ensures uniform blending of polishing compound



POLISHING MEDIAS

Part No.	Item Description
MA 5238	Polishing Media: Walnut 20/30 shell (50 lb.)
MA 5912	Polishing Media: Plastic (50 lb.)
MA 5237	Polishing Compound (1 gal.)
MA 5913	Impregnation Oil (not shown)

STAINLESS STEEL POLISHING STATION

Quickly remove J-hook and burrs while restoring land to punch tips. Unsewn buffing wheels restore luster to punch cups, helping with tablet release. Deburring wheels help remove gouges, which can lead to discoloration or rust on punch barrels and excessive cam wear. **The Polishing Station provides the ONLY method that removes J-hook and restores land to the punch tip.**

FEATURES:

- Polished 18-gauge brushed stainless steel
- Dust hood with light and top shelf
- Main access door with safety switch
- Easy access to filters for simple replacement
- Dual downdraft vacuum system
- Safety cover

EXTERIOR DIMENSIONS

- **Base footprint:** 34.25 x 16" (870 x 406 mm)
- **Floor to top of cabinet:** 37" (940 mm)
- **Across front:** 46 x 20" (1168 x 508 mm)
- **Floor to top of shelf:** 52.5" (1334 mm)

POLISHING STATION INCLUDES:

- Six replacement filters
- Two unsewn 10" buffing wheels
- 8" deburring wheel
- Two deburring wheel hubs
- White fine rouge bar
- Abrasive dressing stick
- *Experts Guide to Tool Polishing DVD*



STAINLESS STEEL POLISHING STATION

Part No.	Item Description
MA 5501	Complete Polishing Station (115v)
MA 5601	Complete Polishing Station (220v)
MA 5502	6-Replacement Filters for MA 5501 or MA 5601 (not shown)
MA 5095	Floor Mat 36 x 24" (914.4 x 609.6 mm)



ACCESSORIES FOR THE STAINLESS STEEL POLISHING STATION

40-PLY UNSEWN BUFFING WHEELS

The **BEST** and **ONLY** method to polish and remove J-hook. Also removes burrs and sharp ridges and is suitable for round, oval, or embossed single and multi-tip tooling.



Unsewn Buffing Wheel in action



40-PLY UNSEWN BUFFING WHEELS

Part No.	Item Description	Size
MA 5063	6" Unsewn Buffing Wheel	½" (12.7 mm) ID
MA 5073	8" Unsewn Buffing Wheel	½" (12.7 mm) ID
MA 5076	10" Unsewn Buffing Wheel	⅝" (15.88 mm) ID
MA 5176	10" Unsewn Buffing Wheel	¾" (19.05 mm) ID
MA 5078	12" Unsewn Buffing Wheel	1¼" (31.75 mm) ID

DEBURRING WHEEL AND HUBS

Removes discoloration, rust and foreign materials from punch barrels, head angles, die ODs, and die faces. *Deburring wheel must be used with hub.*



For use with old-style motors only. Not required with MA 4042 or MA 4047 motors (see page 76).

DEBURRING WHEEL AND HUBS

Part No.	Item Description	Size
MA 5044	Deburring Wheel*	8 x 2 x 3" (203.2 x 50.8 x 76.2 mm)
MA 5046	Deburring Wheel Hub (set of 2)	¾" (19.05 mm)
MA 5048	Deburring Wheel Hub	⅝" (15.88 mm)

***Do not use on head flat.** It may alter critical punch working length. Use on head angles, head OD and barrels only. Use Abrasive Dressing Stick (MA 5010—see page 77) to keep deburring wheel clean and flat.

PUNCH POLISHING MOTORS

- CE compliant
- Safety cover
- 60 Hz, single-phase
- ¾ hp (3450 rpm)
- 5/8" diameter shaft
- Wheels not included



PUNCH POLISHING MOTORS

Part No.	Item Description
MA 4042	115v Dual-Shaft Buffer Motor
MA 4047	220v Dual-Shaft Buffer Motor

BENCH-MOUNTED HOODS WITH TOP SHELF FOR POLISHING MOTOR*

Protective hood with top shelf and exhaust ports mounts to worktable and is used with polishing motors. Sized 36 x 16 x 16" (914 x 406 x 406 mm).



Shown with MA 4042 (Punch Polishing Motor)

BENCH-MOUNTED HOODS

Part No.	Item Description
MA 5057	18-Gauge Galvanized Steel Hood
MA 5058	18-Gauge 300-Series Stainless Steel Hood

SERIES 10 HAND POLISHING KIT

Excellent for polishing punch faces with moderate to severe abrasion.

- Back-mounted on/off switch for safety
- CE compliant

COMPLETE KIT INCLUDES:

- 22,000 rpm, 115v with ¼" Collet
- ⅛" Precision Collet insert
- Two special narrow wrenches
- Abrasive Dressing Stick 1 x 1x 6"
- Green #45 Fine Diamond Compound
- 12 Felt Bobs: ¾ x ¾" (19.05 x 19.05 mm)
- 12 Felt Bobs: ⅝ x ⅝" (9.52 x 9.52 mm)
- 12 Felt Bobs: ½ x ½" (12.7 x 12.7 mm)
- 12 Felt Bobs: ¼ x ⅜" (6.35 x 9.52 mm)
- 12 Felt Bobs: 1 x 1" (25.4 x 25.4 mm)



SERIES 10 HAND POLISHING KIT

Part No.	Item Description
MA 5045	Complete Hand Polishing Kit with Molded Case

NATOLI COMPLETE POLISHING KIT

Maintain and polish all shapes and sizes of tooling with the complete polishing kit. It comes equipped with a foot control and bench mount for maximum hands-free efficiency. **cCSAus approved.**

COMPLETE KIT INCLUDES:

- Hand polishing motor with foot speed control
- Clamp-on weighted hand piece stand
- Flexible shaft with sheath
- Hand piece for shaft with chuck key
- 24 Fine Dental Brushes 0.0925" (2.34 mm) shank
- 12 White Nylon Dental Brushes 1" (25.4 mm) dia.
- 12 White Nylon Brushes ¾" (19.05 mm) dia.
- 12 Felt Bobs: ¾ x ¾" (19.05 x 19.05 mm)
- 12 Felt Bobs: ⅝ x ⅝" (9.52 x 9.52 mm)
- 12 Felt Bobs: ½ x ½" (12.7 x 12.7 mm)
- 12 Felt Bobs: ¼ x ⅜" (6.35 x 9.52 mm)
- Abrasive Dressing Stick
- White Rouge Bar
- 320 Grit Deburring Stone
- 400 Grit Deburring Stone
- One Green Chrome Gloss Bar
- Six 6" Phenolic Embossing Picks
- Green #45 Fine Diamond Compound
- 3-In-1 Stoning Oil
- White Polishing Paste



NATOLI COMPLETE POLISHING KIT

Part No.	Item Description
MA 5001	110/115v Complete Polishing Kit
MA 5000	220/230v Complete Polishing Kit

MUST HAVE!

ABRASIVE DRESSING STICK

Quickly and easily conditions Deburring Wheel surface. Aids in achieving proper cup profile for Felt Bobs.



ABRASIVE DRESSING STICK

Part No.	Item Description	Size
MA 5010	Abrasive Dressing Stick	6 x 1 x 1" (152.4 x 25.4 x 25.4 mm)

DEBURRING STONES

Manually removes burrs and J-hooks on punch tips, which cause capping and lamination. Removes burrs on die ODs and restores land on punches. *Lubricate with Stoning Oil (MA 5020) for better cutting action.*



DEBURRING STONES

Part No.	Item Description	Size
MA 5019	320 Grit	6 x ½ x ½" (152.4 x 12.7 x 12.7 mm)
MA 5016	400 Grit	6 x ½ x ½" (152.4 x 12.7 x 12.7 mm)
MA 5020	Stoning Oil	4 oz. (113.4 g)

MUST HAVE!

FINE DENTAL BRUSHES

Ideal for light to medium punch cup polishing on plain or embossed tools. For use with the Natoli Complete Polishing Kit (see page 77).



FINE DENTAL BRUSHES		
Part No.	Item Description	Shank
MA 5004	Fine Dental Brushes (12-pack)	0.09" (2.29 mm)

NYLON BRUSHES

For use with the Natoli Complete Polishing Kit (see page 77) to polish punch cups.



NYLON BRUSHES		
Part No.	Brush Diameter	Shank
MA 5027	1" (25.4 mm)	0.09" (2.29 mm)
MA 5028	¾" (19.05 mm)	0.09" (2.29 mm)

FELT BOBS

For use with a handheld polisher for medium to heavy punch cup polishing on non-embossed tools. 12-pack.

- Use Abrasive Dressing Stick (see page 77) to form to the punch cup radius



FELT BOBS		
Part No.	Felt Bob Diameter	Shank
MA 5106	1 x 1" (25.4 x 25.4 mm)	½" (3.18 mm)
MA 5006	¾ x ¾" (19.05 x 19.05 mm)	½" (3.18 mm)
MA 5008	½ x ½" (12.7 x 12.7 mm)	½" (3.18 mm)
MA 5007	¾ x ¾" (9.53 x 9.53 mm)	½" (3.18 mm)
MA 5009	¼ x ¾" (6.35 x 9.53 mm)	½" (3.18 mm)

DIE BORE CLEANING BRUSHES

Cleans die bore to prevent lower punch tips from binding in the die.



DIE BORE CLEANING BRUSHES	
Part No.	Brush Diameter
SU 0107	¼" (6.35 mm)
SU 0108	⅜" (9.52 mm)
SU 0109	½" (12.7 mm)
SU 0110	⅝" (15.87 mm)
SU 0111	¾" (19.05 mm)
SU 0112	⅞" (22.22 mm)
SU 0113	1" (25.4 mm)

6" LINEN PHENOLIC EMBOSSING PICKS

Lint-free picks remove stubborn product from hard-to-reach places.

FEATURES:

- Non-scratch material, perfect for punch faces



6" LINEN PHENOLIC EMBOSSING PICKS	
Part No.	Item Description
MA 7515	6" Linen Phenolic Embossing Picks

FINE SCOTCH-BRITE PADS

For use to remove surface discoloration.

- 6 x 9" (152.4 x 228.6 mm)

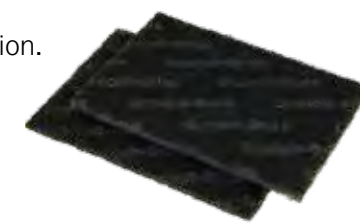

FINE SCOTCH-BRITE PADS	
Part No.	Item Description
MA 5030	Fine Scotch-Brite Pads (20-pack)

COTTON-TIPPED APPLICATORS

For use when applying diamond compound and for cleaning punch cups.

- 3" (76.2 mm) length



COTTON-TIPPED APPLICATORS	
Part No.	Item Description
MA 3020	Cotton-Tipped Single Applicator (100/Bag)

HEAVY-DUTY WORK WIPES AND DISPENSER

Wipes remove excess dirt and grime before, and polishing compounds after, tool polishing. Convenient dispenser keeps quarter-fold wipes organized.



HEAVY-DUTY WORK WIPES AND DISPENSER	
Part No.	Item Description
MA 3010	¼ Fold Heavy-Duty Work Wipes—12 x 13" 75/Box
MA 3015	¼ Fold Work Wipes Dispenser

POLISHING COMPOUNDS

Natoli offers a variety of polishing compounds to ensure proper punch maintenance. Fine polishing compounds are used to achieve a mirror finish. Medium compounds are used for a fine finish.

GREEN CHROME GLOSS BAR

- Specially formulated for polishing punch cups of tooling used with sticky products
- Apply to an unsewn buffing wheel before tool reworking
- Use to achieve a fine finish



MA 5301

WHITE ROUGE BAR

- Apply to an unsewn buffing wheel before tool reworking
- Use to achieve a mirror-like finish



MA 5302

GREEN #45 FINE DIAMOND COMPOUND

- For use with felt bobs and fine dental brushes during polishing
- Use to achieve a mirror-like finish



MA 5012

POLISHING PASTE

- For use with felt bobs and fine dental brushes (see page 78) during polishing
- Use for a mirror-like finish



MA 5304

DIAMOND COMPOUND LUBRICANT

- Mix with diamond compound to enhance effectiveness
- For use with fine dental brushes (see page 78) in punch cups



MA 5085

POLISHING COMPOUNDS

Part No.	Item Description
MA 5301	Green Chrome Gloss Bar—6½ x 1½ x 1½" (165.1 x 38.1 x 38.1 mm)
MA 5302	White Fine Rouge Bar—9½ x 2 x 2" (241.3 x 50.8 x 50.8 mm)
MA 5012	Green #45 Fine Diamond Compound—5 g (0.175 oz.)
MA 5304	Polishing Paste—4 oz. (113.4 g)
MA 5305	Polishing Paste—8 oz. (226.8 g)
MA 5085	Diamond Compound Lubricant—1 quart

POLISHING INSTRUCTIONAL DVD

Learn how to properly polish tablet compression tooling with Natoli's *Experts Guide to Tool Polishing* DVD.

POLISHING INSTRUCTIONAL DVD

Part No.	Item Description
SU 9000	Experts Guide to Tool Polishing DVD



LUBRICATION

Natoli lubricants are engineered to maximize tool life and minimize maintenance costs by providing superior protection. Applying one of **Natoli's Food-Grade Lubricants** to tooling will ensure proper lubrication not commonly found on tablet press start-up. A tool that is not properly lubricated will cause excessive friction and lead to emergency stops, tool binding, and tool damage.



H-1 Barrel Lube
Part No. SU 2525

H-1 Synthetic Food-Grade
Grease NLGI Grade #2
Part No. SU 2516

H-1 Barrel Lube
Aerosol Spray
Part No. SU 2521

H-1 Tooling
Storage Protectant
Part No. SU 2545

H-1 Synthetic Food-Grade
Grease NLGI Grade #1
Part No. SU 2532

H-1 Synthetic Food-Grade
Grease NLGI Grade #2
Part No. SU 2512

NATOLI PUNCH AND TABLET PRESS LUBRICANT GUIDE

Premium lubricants for all makes and models of tablet presses.

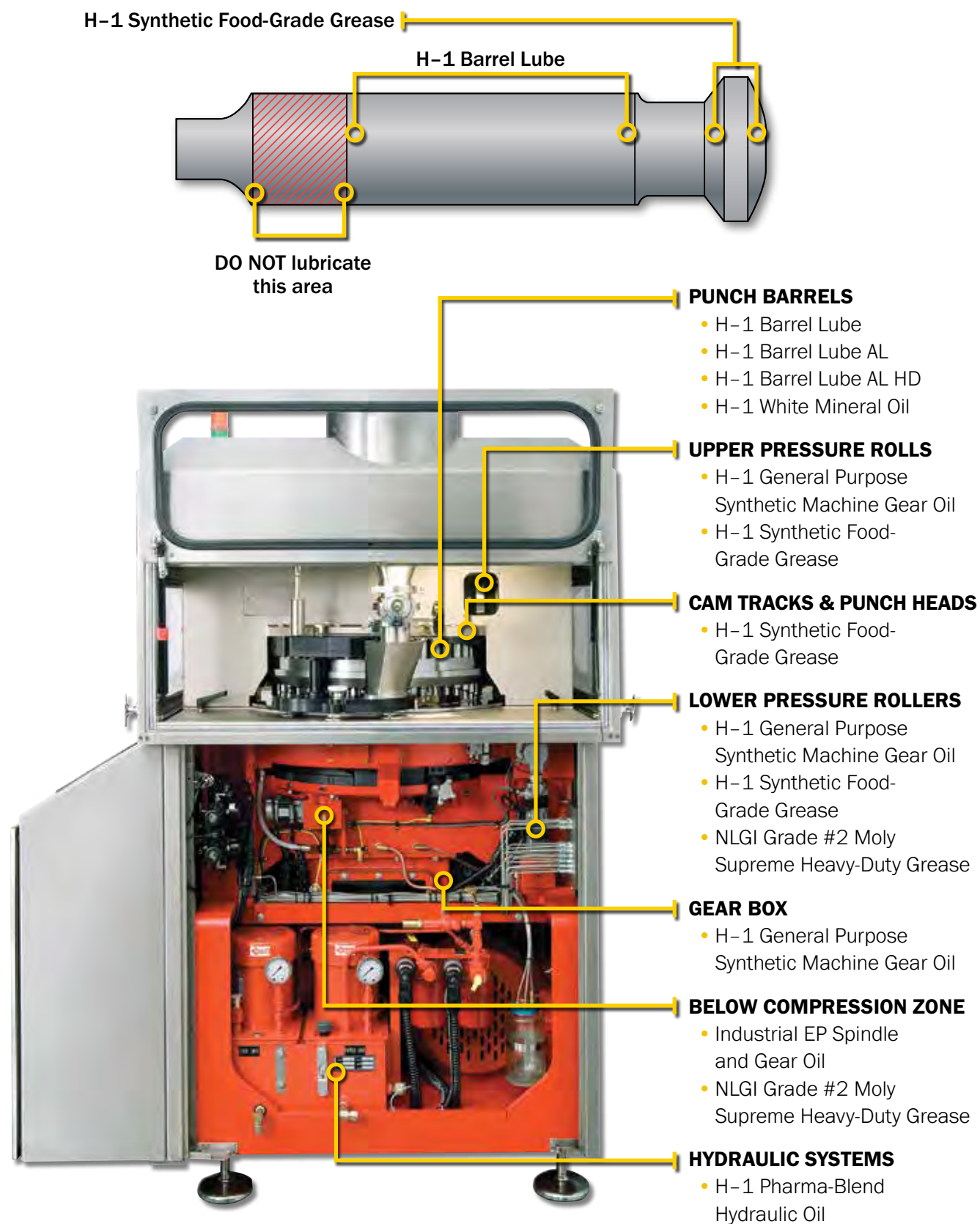

ALL PREMIUM NATOLI FOOD-GRADE LUBRICANTS MEET OR EXCEED USDA H-1 REQUIREMENTS AND FDA REGULATIONS AND ARE KOSHER AND HALAL CERTIFIED.

Natoli's premium quality, tested lubricants will meet or exceed the performance of other manufacturers' products.

- Apply as directed to inhibit oxidation, rust and wear on machinery and tooling
- Use with all processing equipment requiring H-1 lubrication, such as tablet presses, packaging equipment, mixing and blending equipment, etc.
- Safety Data Sheet (SDS) provided with each product

H-1 BARREL LUBE

- Use on punch barrels
- Manual application required
- Food-grade
- SAE 10
- **Not for auto-lube systems**



H-1 BARREL LUBE	
Part No.	Item Description
SU 2521	15 oz. (425 g) Aerosol Can
SU 2525	16 oz. (473 ml) Pump

MUST HAVE!

H-1 BARREL LUBE AL

- *Specially formulated for punch barrel auto-lube systems*
- Food-grade
- SAE 10



H-1 BARREL LUBE AL	
Part No.	Item Description
SU 2530	1 gal. (3.8 L)
SU 2560	5 gal. (18.9 L) Drum

For Auto-Lube Systems

H-1 BARREL LUBE AL HD (AUTO-LUBE HEAVY-DUTY)

Specially formulated heavy-duty punch barrel auto-lube system oil.

- Inhibits rust, corrosion, and wear
- Compatible with all types of seals
- Use where UH 1 150 oil is specified
- Antimicrobial
- Food-grade
- SAE 40



H-1 BARREL LUBE AL HD	
Part No.	Item Description
SU 2555	1 gal. (3.8 L)
SU 2556	5 gal. (18.9 L) Drum with Pull-Out Spout

For Auto-Lube Systems

H-1 NLGI GRADE #1 GREASE

For use on punch heads, pressure rolls, cam tracks or any process requiring a food-grade grease.

- High melting point, anti-wear
- **Fortified with Microshield®**
- Food-grade



H-1 NLGI GRADE #1 GREASE

Part No.	Item Description
SU 2532	14 oz. (414 ml) Tube



H-1 NLGI GRADE #2 GREASE

For use on punch heads, pressure rolls, cam tracks or any process requiring a food-grade grease.

- High melting point, anti-wear
- **Fortified with Microshield®**
- Food-grade

H-1 NLGI GRADE #2 GREASE

Part No.	Item Description
SU 2518	14 oz. (414 ml) Tube
SU 2508	14 oz. (414 ml) Can
SU 2512	7 lb. (3.17 kg) Can
SU 2516	40 lb. (18.14 kg) Drum



H-1 TOOLING STORAGE PROTECTANT

- Ideal for long-term tooling storage
- **Prevents corrosion and discoloration of tools**
- Easy to remove
- Food-grade
- SAE 30, ISO 100

H-1 TOOLING STORAGE PROTECTANT

Part No.	Item Description
SU 2545	1 gal. (3.8 L)

MUST HAVE!



H-1 GENERAL PURPOSE SYNTHETIC MACHINE GEAR OIL

- For use in gear boxes
- Compatible with all types of seals and coatings
- Reduces deposit formation
- Food-grade
- SAE 90



H-1 GENERAL PURPOSE SYNTHETIC MACHINE GEAR OIL

Part No.	Item Description
SU 2533	5 gal. (18.9 L) Drum with Pull-Out Spout

H-1 PHARMA-BLEND HYDRAULIC OIL

Offers excellent stability over a wide temperature range. Pumps run cooler than systems filled with conventional oils virtually eliminating oxidation and varnishing.

- All natural and non-toxic
- Stable from 0–470°F (0–243°C)
- Food-grade
- ISO 46



H-1 PHARMA-BLEND HYDRAULIC OIL

Part No.	Item Description
SU 2537	1 gal. (3.8 L)

H-1 WHITE MINERAL OIL

- **Inhibits rust, oxidation and wear**
- For use on punch barrels
- Food-grade



H-1 WHITE MINERAL OIL

Part No.	Item Description
SU 2527	1 gal. (3.8 L)

ALL PREMIUM NATOLI NON-FOOD-GRADE LUBRICANTS WILL REDUCE MACHINERY AND TOOLING WEAR, EVEN UNDER THE MOST EXTREME PRESSURE.

For use in areas **NOT** requiring food-grade lubrication.

NLGI GRADE #2 MOLY SUPREME HEAVY-DUTY GREASE

- Use on variable-speed pulleys, drive shafts, worm gears, weight cam gear boxes or any area **below the tablet compression zone**
- Blended from 100% pure paraffin-base oils and the finest quality synthetic stocks
- Non-food-grade



NLGI GRADE #2 MOLY SUPREME HEAVY-DUTY GREASE

MUST HAVE!

Part No.	Item Description
SU 2531	14 oz. (414 ml) Tube

INDUSTRIAL EXTREME PRESSURE (EP) SPINDLE & GEAR OIL

- Non-foaming
- Anti-wear
- Non-food-grade
- SAE 90



INDUSTRIAL EXTREME PRESSURE (EP) SPINDLE & GEAR OIL

Part No.	Item Description
SU 2515	½ gal. (1.9 L)

HEAVY-DUTY GREASE GUN

The zinc-plated, heavy-duty, lever-action grease gun features a rugged cast iron head with versatile three-way loading and is capable of delivering up to 10,000 PSI. A flexible 12" (304.8 mm) hose and coupler are included to allow easy access to hard-to-reach areas.



HEAVY-DUTY GREASE GUN

Part No.	Item Description
SU 2547	Zinc-Plated Grease Gun
SU 2548	12" (304.8 mm) Hose and Coupler Only

STORAGE SOLUTIONS

Tooling wear and damage caused by mishandling may cause black specks and product discoloration as well as capping, lamination, and other visual tablet defects. A systematic storage and handling procedure can be as simple as using **Natoli's Tooling Storage Boxes**, which safely store and protect punches and dies and are made from FDA-compliant materials. Natoli can also create customized storage solutions for your unique tool configurations, such as Kilian 20/28, FS12, FS19, and more!

"B" Type Tooling Storage Box in Red
Part No. MA 5178R



"B" Type Tooling Storage Box in Cream
Part No. MA 5178

"B" Type Tooling Storage Box in Black
Part No. MA 5178B

TOOLING STORAGE BOXES

Safely store and protect punches and dies with Natoli's Tooling Storage Boxes and Tooling Storage Box Trays. Constructed of easy-to-clean, FDA-compliant materials, each box contains an easy lift-out tray and nested lid for stacking. **Available in cream, red, and black to differentiate tools for better organization!**

BOX FEATURES:

- Recessed handles to ensure secure handling
- Nested lid design that allows for stacking of multiple boxes

TRAY FEATURES:

- Enables tooling to be easily stored together in sets
- Molded keyways and guides prevent tool damage
- Head support enables easy tool removal
- Removable tray allows interchanging of four different tooling sizes
- Includes drainage holes for water and excess oil to escape
- **Optional handle kit allows for ease of use in multiple applications such as Ultrasonic Cleaning Systems (see pages 40–41)**

BOX EXTERIOR DIMENSIONS (L X W X H):

- 18 x 11 x 7" (457 x 279 x 178 mm)



Handle and Leg Kit Shown on Removable Tray



TRAY CAPACITIES:

- **"B"**: 72 punches + 38 dies (1.187"/30.149 mm dia.) or 72 punches + 48 dies (0.945"/24.003 mm dia.)
- **"D"**: 48 punches + 24 dies (1.50"/38.1 mm dia.)
- **533/328-45**: 45 punches + 24 dies (1.312"/33.324 mm die dia.)
- **533/328-33**: 33 punches + 24 dies (1.625"/41.275 mm die dia.)

TOOLING STORAGE BOXES

Part No.	Punch Type (Barrel Diameter)	Color
MA 5178	"B" (3/4")	Cream
MA 5178R	"B" (3/4")	Red
MA 5178B	"B" (3/4")	Black
MA 5185	"B" Handle Kit	—
MA 5180	"D" (1")	Cream
MA 5180R	"D" (1")	Red
MA 5180B	"D" (1")	Black
MA 5187	"D" Handle Kit	—
MA 5083	533/328-45 (1 1/8")	Cream
MA 5086	533/328-33 (1 1/4")	Cream



TOOLING STORAGE BOXES REPLACEMENT ITEMS

Part No.	Item Description	Color
MA 5184	"B" Tray	Cream
MA 5184R	"B" Tray	Red
MA 5184B	"B" Tray	Black
MA 5186	"D" Tray	Cream
MA 5186R	"D" Tray	Red
MA 5186B	"D" Tray	Black
MA 6030	533/328-45 Tray	Cream
MA 6029	533/328-33 Tray	Cream
MA 5182	Box	Cream
MA 5182R	Box	Red
MA 5182B	Box	Black
MA 5183	Lid	Cream
MA 5183R	Lid	Red
MA 5183B	Lid	Black

TOOLING STORAGE BOX TRANSPORT CART

SAFELY transport and store tooling storage boxes in this heavy-duty, FDA-compliant cart. The cart includes a lockable tool drawer and two Lista® roll-out trays.

FEATURES:

- One 3" (76.2 mm) depth tool drawer and two roll-out trays
- Heavy-duty casters 4 x 2" (101.6 x 50.8 mm)
- Retainer top with ribbed matting
- Chrome push handles (not shown)
- Cabinet with keyed lock
- Constructed of cold rolled steel (CSR)
- **Carts can be specially ordered to accommodate customer needs**

DIMENSIONS (W X D X H):

- 28.5 x 28.5 x 38.75" (717.55 x 723.9 x 984.25 mm)



TOOLING STORAGE BOX TRANSPORT CART

Part No.	Item Description
LE 3027	Tooling Storage Box Transport Cart

DIE SEGMENT STORAGE SYSTEM

Make the storage, transport, and set-up of die segments easier than ever! The heavy-duty Die Segment Mobile Cabinet is the safest method for transporting segments without damage. Stationary cabinet also available.

This system meets FDA guidelines.

FEATURES INCLUDE:

- Four 900 lb. (408.23 kg) capacity, never-go-flat casters
- Lockable, size-adjustable drawers capable of holding eight die segments each
- Tubular steel handles for easy handling
- Top drawer equipped with non-slip liner for storage of set-up tools
- Optional drawer dividers available for greater organization
- **Custom or modified cabinets are available upon request**

DIMENSIONS (W X D X H):

- **LE 3015:** 22 x 28.5 x 34" (564 x 725.5 x 857 mm)
- **LE 3016:** 44 x 28.5 x 33.5" (1,127 x 725.5 x 851 mm)
- **LE 3026:** 22.2 x 28.5 x 34.9" (564 x 725.5 x 886.5 mm)

Double Mobile Cabinet

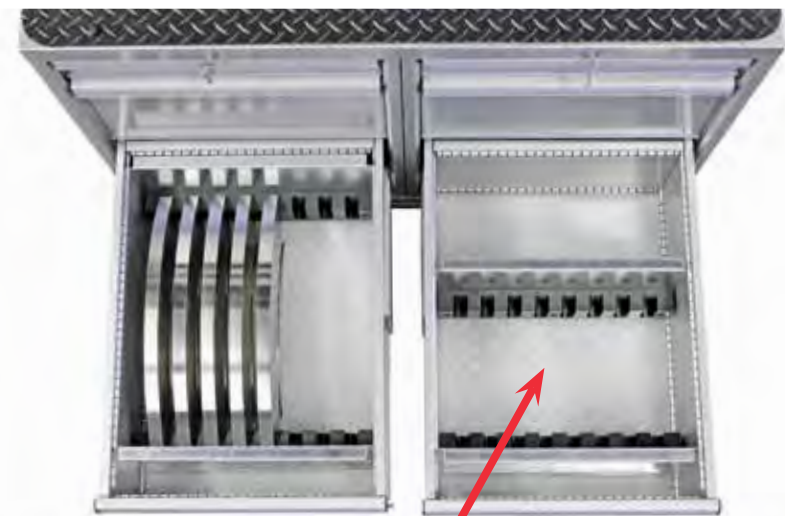

CUSTOMIZABLE DRAWERS

Customize each drawer easily without the need for tools. Each drawer adjusts to hold any size die segment, making special order dividers unnecessary.



DIE SEGMENT STORAGE SYSTEM

Part No.	Item Description	Capacity
LE 3015	Single Mobile Cabinet	16 Segments
LE 3016	Double Mobile Cabinet	32 Segments
LE 3026	Stationary Cabinet	24 Segments
LE 3017	Black Diamond Mat Top for LE 3015	—
LE 3018	Black Diamond Mat Top for LE 3016	—
LE 3021	Tool Drawer Dividers	—



Stationary Cabinet



Mobile Cabinet

DIE SEGMENT STORAGE BOXES AND TRANSPORT CART

Safely store and transport die segments with heavy-duty, FDA-compliant storage boxes. The two-piece design features rugged construction with a foam insert ensuring secure storage for valuable die segments. Built-in side ID tag allows for easy identification.

FEATURES:

- Two-piece construction
- Molded foam insert
- Stackable
- Works with other storage solutions



Segment Storage Box Cart



Storage cart features adjustable shelving that can fit up to five die segment storage boxes.

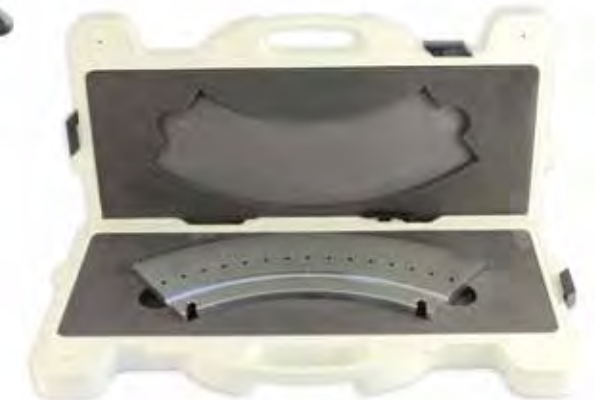

DIE SEGMENT STORAGE BOXES AND TRANSPORT CART

Part No.	Item Description	Capacity
MA 5650 KIT	Storage Box for 1090 or 1200 Die Segments	2 Segments
MA 5660 KIT	Storage Box for 2090 Die Segments	1 Segment
MA 5670 KIT	Storage Box for 3090 Die Segments	1 Segment
MA 5680 KIT	Segment Storage Box FE-55	1 Segment
MA 5690 KIT	Segment Storage Box FE-35	1 Segment
MA 5685 KIT	Segment Storage Box FE-75	1 Segment
LE 3025	Segment Storage Cart	—

PUNCH & DIE STORAGE SYSTEM

Protect your investment with proper storage. This rugged punch and die storage system makes storage, transportation and inspection of tools convenient and efficient. **This system meets FDA guidelines.**

1 TOOLING STORAGE CABINET

CAPACITY:

- Each cabinet includes four drawers with a maximum capacity of six drawers
- Each drawer has a maximum capacity of four tool holders (see step 3)

DIMENSIONS (W X D X H):

- 28.25 x 29.5 x 59.5" (718 x 749 x 1511 mm)

2 TOOLING TRANSPORTER UNIT

Safely transport tools with this unit.

CAPACITY:

- Four tool holders (see step 3)

DIMENSIONS (W X D X H):

- 39 x 20 x 36.5" (991 x 508 x 927 mm)



3 TOOL HOLDERS

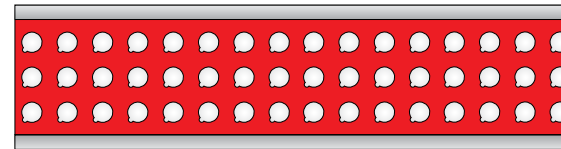

Standard "B" Punch Holder

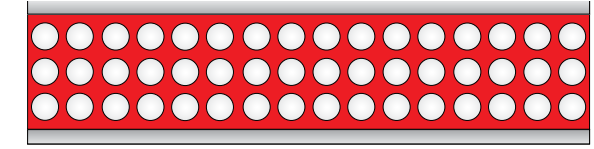

Standard "BB" Die Holder

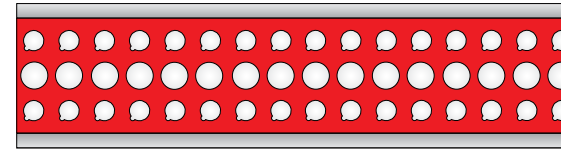

Standard "B" Punch & Die Combination Holder



The tool holders feature handles for easy transfer of multiple punches and dies from storage cabinet to transporter. No tools are required, and multiple layouts are available.



PUNCH & DIE STORAGE SYSTEM

Part No.	Punch Type (Barrel Diameter)	Capacity
LE 3010	Tooling Cabinet (includes 4 drawers and 16 pairs of brackets)	—
LE 3004	Tooling Transporter (includes four pairs of 20° brackets)	—
LE 3000	"B" (3/4"/19.05 mm) Punch Only Holder	48 Punches
LE 3022	"B" (1.1875"/30.16 mm) Die Only Holder	35 Dies
LE 3013	"BB" (0.945"/24 mm) Die Only Holder	48 Dies
LE 3023	"B" (3/4"/19.05 mm) Punches and "B" (1.1875"/30.16 mm) Dies Combination Holder	30 "B" Punches + 15 "B" Dies
LE 3011	"B" (3/4"/19.05 mm) Punches and "BB" (0.945"/24 mm) Dies Combination Holder	32 "B" Punches + 16 "BB" Dies
LE 3001	"D" (1"/25.4 mm) Punch Only Holder	36 Punches
LE 3014	"D" (1.50"/38.1 mm) Die Only Holder	35 Dies
LE 3012	"D" (1"/25.4 mm) Punches and "D" (1.50"/38.1 mm) Dies Combination Holder	24 "D" Punches + 12 "D" Dies
LE 3024	Extra Drawer and Brackets for LE 3010	—
LE 3005	Pair of Extra Brackets (Straight)	—
LE 3006	Pair of Extra Brackets (20° Angle)	—

CHROME WIRE SHELVING

Save valuable space with the ideal solution for general storage. Chrome Wire Shelving units can be used individually or can be connected to increase storage capacity. **Purchase optional locking casters to create a mobile unit.**

FEATURES:

- Shelves adjust on 1" (25.4 mm) increments
- Posts are constructed of 1" (25.4 mm) round 16-gauge tubing
- Promotes air circulation
- Does not block lighting
- Flexible for growth and room layouts
- **Specialty sizes can be ordered**

SHELF LENGTH AND CAPACITY:

- 48" (1.219 m) or less—1000 lb. (453.59 kg)
- 60" (1.524 m)—800 lb. (362.87 kg)
- 72" (1.828 m)—600 lb. (272.15 kg)

STARTER UNITS:

- Includes four posts and five shelves

ADD-ON UNITS:

- **Starter unit required to use add-on units**
- Includes two posts, five shelves and 10 "S" hooks

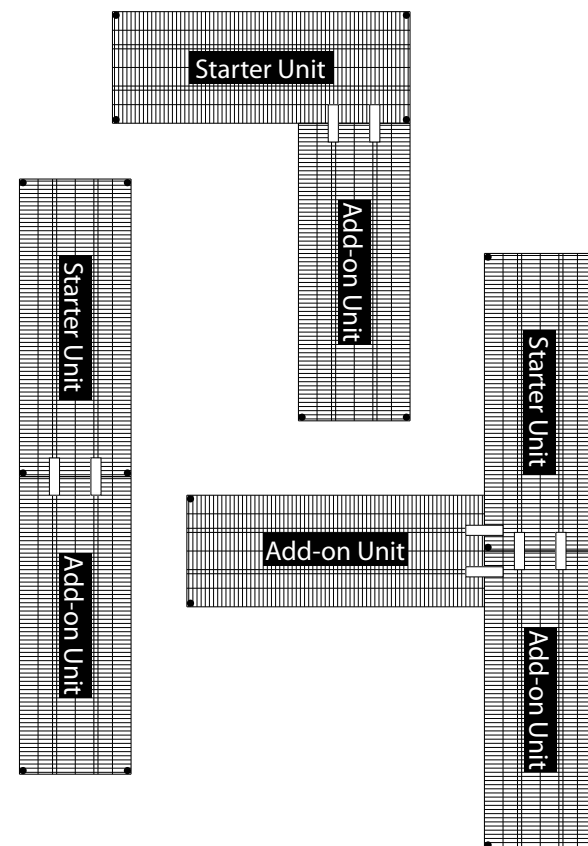

CHROME WIRE SHELVING

Part No.	Item Exterior Dimensions	
MA 6042	36 x 24 x 72" (0.914 x 0.610 x 1.829 m)	Starter Unit
MA 6043	42 x 24 x 72" (1.067 x 0.610 x 1.829 m)	Starter Unit
MA 6073	48 x 24 x 72" (1.219 x 0.610 x 1.829 m)	Starter Unit
MA 6074	60 x 24 x 72" (1.524 x 0.610 x 1.829 m)	Starter Unit
MA 6075	72 x 24 x 72" (1.829 x 0.610 x 1.829 m)	Starter Unit
MA 6095	36 x 24 x 72" (0.914 x 0.610 x 1.829 m)	Add-On Unit
MA 6096	42 x 24 x 72" (1.067 x 0.610 x 1.829 m)	Add-On Unit
MA 6097	48 x 24 x 72" (1.219 x 0.610 x 1.829 m)	Add-On Unit
MA 6098	60 x 24 x 72" (1.524 x 0.610 x 1.829 m)	Add-On Unit
MA 6099	72 x 24 x 72" (1.829 x 0.610 x 1.829 m)	Add-On Unit
MA 7010	36 x 24" (914 x 610 mm)	Individual Shelf
MA 7011	42 x 24" (1067 x 610 mm)	Individual Shelf
MA 7012	48 x 24" (1219 x 610 mm)	Individual Shelf
MA 7013	60 x 24" (1524 x 610 mm)	Individual Shelf
MA 7014	72 x 24" (1829 x 610 mm)	Individual Shelf
MA 6071	Set of 4 Locking Casters	

SECURITY STORAGE SHELVING

Secure tooling, tablets, and other valuables with lockable, nickel-plated, chrome-wire Security Storage Shelving. Optional casters create a mobile unit. **Custom sizes available.**

FEATURES:

- Three adjustable shelves
- 1000 lb. (453.59 kg) weight capacity per shelf
- Lockable front door handle

OPTIONAL LOCKING CASTERS:

- Non-marking, stem swivel casters
- Provides shock-free mobility for shelving units
- Supports up to 1000 lb. (453.59 kg)
- 5 x 1.25" (127 x 31.75 mm)



SECURITY STORAGE SHELVING

Part No.	Item Exterior Dimensions
MA 6093	48 x 24 x 60" (1.219 x 0.610 x 1.524 m)
MA 6071	Set of 4 Locking Casters

MUST HAVE!

UTILITY CARTS

Transport tooling, parts, and other supplies safely and easily with a utility cart. Natoli carries multiple styles of carts to suit your transportation needs.

CHROME WIRE UTILITY CARTS

- Two or three shelf models available
- 3" (76.2 mm) donut bumpers
- Includes 4" (101.6 mm) locking casters
- Convenient push handles
- 1200 lb. (544.31 kg) capacity



CHROME WIRE UTILITY CARTS

Part No.	Shelf Dimensions (L x W)
MA 6040	2 shelves—36 x 18" (914 x 457 mm)
MA 6041	3 shelves—36 x 18" (914 x 457 mm)

STAINLESS STEEL UTILITY CART

- Stainless steel construction
- Two swivel and two locked casters
- 1200 lb. (544.31 kg) capacity



STAINLESS STEEL UTILITY CART

Part No.	Shelf Dimensions (L x W X H)
MA 2001	24 x 36 x 35" (610 x 914 x 889 mm)



POLYPROPYLENE UTILITY CARTS

Utility carts clean easily, making them ideal for a variety of uses.

- Won't chip, rust, or dent
- Includes 5" (127 mm) swivel casters
- 500 lb. (226.79 kg) capacity



POLYPROPYLENE UTILITY CARTS

Part No.	Shelf Dimensions (L x W X H)
MA 6000	40 x 18 x 33" (1016 x 457 x 838 mm)
MA 6002	45 x 25 x 33" (1143 x 635 x 838 mm)

CLEAR MEMBRANE PLASTIC TABLET STORAGE BOX

Enable inspection of tablets without physical contact.

- Membrane suspends tablet for easy 360° viewing



PLASTIC TABLET STORAGE BOX

Part No.	Item Description
MA 7006	1.25" (31.75 mm) Plastic Tablet Storage Box (Pack of 12)



EQUIPMENT COVERS

Economical, FDA-compliant covers facilitate the clean and dry storage of various types of equipment in a wide selection of sizes. **Custom sizes also available.**

STANDARD EQUIPMENT COVERS:

- Constructed of anti-static polyethylene
- Transparent pink color
- Elastic band at bottom

CUSTOM EQUIPMENT COVERS:

- Constructed of 3-ply vinyl laminate
- Solid white color
- Zipper
- Features Natoli logo

Custom Equipment Cover



Standard Equipment Cover



EQUIPMENT COVERS

Part No.	Dimensions/Item Description
LE 7054	10-14" (254-356 mm)
LE 7053	20-24" (508-610 mm)
LE 7055	60 x 48 x 76" (1.524 x 1.219 x 1.930 m)
LE 7056	64 x 60 x 82" (1.626 x 1.524 x 2.083 m)
LE 7051	Equipment Cover for Natoli LVS System
LE 7050	Custom Equipment Cover

PROTECTIVE RED CAPS FOR PUNCH TIPS

Protects punch tips during transportation and storage. Assortment contains various sizes and shapes to ensure a secure fit and maximum tip protection.

PROTECTIVE RED CAPS FOR PUNCH TIPS	
Part No.	Item Description
MA 3030	Bag of 250 Red Caps for Punches (asstd. sizes)



REUSABLE PLASTIC DIE STORAGE TUBES WITH RUBBER ENDS

Protect dies during transportation and storage.

REUSABLE PLASTIC DIE STORAGE TUBES		
Part No.	Diameter	Capacity
MA 7020	1.25" (31.75 mm)	15 "B" Dies
MA 7021	1.50" (38.1 mm)	15 "D" Dies



CARDBOARD PUNCH SHIPPING TUBES

Safely ship punches with this economical solution.

CARDBOARD PUNCH SHIPPING TUBES		
Part No.	Punch Type	Tube Length
MA 5066	"B"	5¼" (133.35 mm)
MA 5068	"D"	5¼" (133.35 mm)
MA 5072	DS3	5¼" (133.35 mm)
MA 5070	533/328	7¼" (184.15 mm)



REUSABLE PLASTIC PUNCH AND DIE STORAGE TUBES

Protects punches during storage or shipping. Constructed of transparent, moisture-resistant plastic, the square shape prevents rolling and accidental damage.

- Telescoping length adjustment (4.75–7.875"/120.65–200 mm)



REUSABLE PLASTIC PUNCH STORAGE TUBES			
Part No.	Type	Barrel Diameter	Style
MA 7007	"B" Punches	¾" (19.05 mm)	Foam insert not required
MA 7016	"B" Die Storage	1" (25.4 mm)	Foam insert included
MA 7015	"BB" Die Storage	¾" (19.05 mm)	Foam insert included
MA 7008	"D" Punches	1" (25.4 mm)	Foam insert not required
MA 7009	328 or "D" dies	1½–1¼" (28.58–31.75 mm)	Foam insert included

A

- Abrasive Dressing Stick.....77
- Acetal Wash Basin.....45
- Adjustable Torque Screwdriver14
- Alignment Punches, Cam19
- Alkaline Wash Solution, Natoli.....43
- Analytical Balance37
- Applicators, Cotton-tipped.....79
- Automated Polishing Machine.....72
- Automated Polishing Machine Die Holders.....73
- Automated Polishing Machine Punch Holders73

B

- Balances
 - Analytical Balance37
 - Precision Balance38
- Barrel Lube, H-1 Food-Grade83
- Barrel-Lube AL, H-1 Food-Grade83
- Barrel-Lube AL HD, H-1 Food-Grade83
- Barrel-Style Dust Cups24-25
- Baskets, Stainless Steel Wire Tooling42
- Bellows26
- Bench-Mounted Hoods for Polishing Motors76
- Blank Dies17
- Brushes
 - Die Bore Cleaning.....46, 78
 - Die Pocket Side-Action Cleaning.....47
 - Fine Dental78
 - Nylon Polishing.....78
 - Soft-tip Nylon46
 - Steel Brush Holder.....47
 - Turret Guide Cleaning47
 - Ultra-Stiff Nylon Bristle47
- Buffing Motor.....76
- Buffing Wheels, Unsewn.....75

C

- Calibration Punches, Lower.....67
- Cam Alignment Punches19
- Carts
 - Die Segment Storage Box.....91
 - Tooling Storage Box Transport89
 - Utility96
- Certificate of Calibration70
- Certificate of Inspection70
- Chem-Crest Cleaning Solutions
 - Chem-Crest® 25 Wash Solution.....43
 - Chem-Crest® 211 Wash Solution43
 - Chem-Crest® 77G Rinse Solution.....43
- Chrome Wire Shelving94
- Chrome Wire Utility Cart.....96
- Citrus Degreaser
 - Citrus Degreaser, Aerosol45
 - Citrus Degreaser, Heavy-Duty.....44
- Complete Polishing Kit77
- Connecting Cables, SPC.....61
- Cotton-Tipped Applicator79

D

- Deburring Stones77
- Deburring Wheel.....75
- Deburring Wheel Hub75
- Dedusters
 - Combined Unit30
 - Drum-Style29
 - Natoli Uphill.....28
 - Stainless Steel.....28
 - Telescopic29
- Degreaser
 - Citrus, Aerosol.....45
 - Citrus, Heavy-Duty44
 - Food-Grade45
- Dial Indicator Replacement Tips62
- Dial Indicators56, 62
- Dial Micrometer64
- Diamond Compound, Green #45 Fine.....80
- Diamond Compound Lubricant80
- Die Bore Cleaning Brushes46, 78
- Die Bore Gauge Test Stand.....58
- Die Driving Rod Replacement Tips.....16
- Die Driving Rods.....16
- Die Insertion Rings.....16
- Die Lock Hex Adapter15
- Die Lock T-Handle Wrench15
- Die Pocket Gauges67
- Die Pocket Side-Action Cleaning Brush.....47
- Die Seat Cleaner Tools17
- Die Segment Storage Boxes.....91
- Die Segment Storage System.....90
- Die Segment Transport Cart91
- Die Storage Tube98
- Digimatic Mini-Processor61
- Digital Calipers with Absolute Encoder63
- Digital Immersion Thermometer.....41
- Digital Indicator56, 62
- Digital Micrometer64
- Digital Microscope.....59-60
- Digital Torque Analyzers (VeriTorq®)14
- Disintegration Tester, Dual-Station.....36
- Dust Cup Cutting Tool.....23
- Dust Cups
 - Barrel-Style24-25
 - EU1/441 Barrel-Style25
 - Tip-Mounted.....22-23

E

- Embossing Picks, Linen Phenolic.....46, 79
- Equipment Covers97
- Ergonomic Preset Torque Screwdriver.....14
- EU1/441 Barrel-Style Dust Cups.....25
- Euro-Style Bellows and Retaining Ring26

F

- Facemask, Protectant48
- Feather Keys21

F	
Feeler Gauges, Precision	15
Felt Bobs	78
Fine Dental Brushes.....	78
Fixed Parallel Key (Feather Keys).....	21
FM Krystall Food-Grade Cleaner.....	44
Food-Grade Degreaser.....	45
Food-Grade Lubricants, H-1.....	83-85
Friability Tester	36
G	
Granite Gauge Stand.....	56
Grease Gun, Heavy-Duty.....	86
Green #45 Fine Diamond Compound.....	80
Green Chrome Gloss Bar	80
H	
Hand Polishing Kit, Series 10	76
Handheld Magnifier and Eye Loupe	69
Hardness Testers	
Portable Handheld Hardness Tester	34
Stainless Steel Handheld Tablet Hardness Tester	34
Tablet Hardness & Thickness Tester, 3-in-1	35
Head Gauge Go/No-Go	66
Heat Gun	48
Heavy-Duty Work Wipes	79
Height Standard Validation Gauges.....	61
Hi-Pro Press-In Key.....	21
Hi-Pro Screw-In Key	21
Horizontal Optical Comparator	50
Hydraulic Oil, H-1 Pharma-Blend.....	85
I	
Impregnation Oil	73
Indicator Lifting Lever.....	56
Indicator Magnetic Base	56
Industrial Extreme Pressure Spindle and Gear Oil.....	86
Inspection Gauge, Turret Keyway	68
Inspection Kits, Turrets Certified.....	67
Inspection Mirror.....	20
K	
Keychain Light.....	70
Key Gauges	66
Key Screws, Stainless Steel	21
L	
L-Handle Torque Wrench.....	13
Laser Vision Punch Inspection System	52
LED Magnifiers	69
Linen Phenolic Embossing Sticks.....	46, 79
Lint-Free Wiping Cloths.....	48
Load Cell Indicator	11
Lower Calibration Punches.....	67
Lower Punch Seal Stop Installation Tool	19
Lubricants	
Food-Grade.....	83-85
Non-Food-Grade	86

M	
Magnifiers.....	69
Metal Detector	30
Metal Inspection Mirror.....	20
Micrometers	
Dial.....	64
Digital with Absolute Encoder.....	64
Micrometer Stand	64
Microscopes	
Deluxe Digital Handheld	59
Handheld Digital with LCD	60
Mineral Oil, White	85
Mini-Processor/Printer	61
Moly-Supreme Heavy-Duty Grease	86
Multi-Tip Maintenance Kit.....	12
Multi-Tip/Rotating Head V-Block Kit.....	65
N	
Natoli Alkaline Wash Solution.....	43
Natoli Polishing Compound	73
NLGI Greases	
Grade #1, Food-Grade	84
Grade #2, Food-Grade.....	84
Grade #2 Moly Supreme, Non-Food-Grade.....	86
Non-Food-Grade Lubricant.....	86
Nylon Polishing Brush.....	78
O	
Oils	
Gear, Food-Grade and Non-Food-Grade.....	85-86
Hydraulic, Food-Grade.....	85
White Mineral, Food-Grade.....	85
Outside Micrometers.....	62
Overload and Strain Gauge Calibration Kit.....	11
Overload and Strain Gauge Calibration Punches.....	11
P	
Pharma-Blend Hydraulic Oil	85
PK2 Cleaner	45
Plastic Polishing Media	73
Pneumatic Conveyor.....	32
Pneumatic Drill	20
Polishing Instructional DVD.....	80
Polishing Kits	
Complete.....	77
Hand	76
Polishing Machine, Automated.....	72
Polishing Medias	
Plastic Polishing Media.....	73
Walnut Polishing Media	73
Polishing Paste	80
Polishing Stations.....	74
Polypropylene Utility Carts	96
Preset Torque Wrenches	13
Precision Balance.....	38
Precision Feeler Gauges	15
Precision Straight Edge	18
Premium LED Handheld Magnifiers	69

Press Set-Up Toolboxes	10
Protective Punch Caps	98
Punch and Die Storage System.....	92-93
Punch Guide Plugs	17
Punch Guide Seal Installation Tool.....	18
Punch Holders.....	56, 69
Punch Holding Trays	68
Punch Inspection System, LVS	52
Punch Key Gauges	66
Punch Polishing Motors.....	76
Punch Replacement Keys	21
Punch Seal Removal Tool	18
Punch Shipping Tubes.....	98
Punch Storage Tubes.....	98

R	
Right Angle Pneumatic Drill	20
Rotating Head Maintenance Kit.....	12
Rotating Head/Multi-Tip V-Block Kit.....	65

S	
Scoops, Stainless Steel.....	20
Scotch-Brite Pads, Fine	79
Seal Stop Installation Tool, Lower Punch	19
Security Storage Shelving.....	95
Segment Storage Boxes	91
Segment Storage System	90
Series 10 Hand Polishing Kit	76
Shelving.....	94-95
Silicone Bellows.....	26
SPC Connecting Cables.....	61
Split Ball Bore Gauges (Probe Set).....	58
Spray Bottle, 2-Pack.....	48
Stainless Steel Dry Cleaner, Aerosol.....	45
Stainless Steel Key Screws	21
Stainless Steel Wire Tooling Baskets	42
Stainless Steel Tooling Trays.....	41
Stainless Steel Utility Cart.....	96
Steel Brush Holder	47
Stoning Oil	77
Storage Shelving.....	94-95
Storage Systems	
Die Segment	90-91
Punch & Die	92-93
Straight Edge, Precision	18
Synthetic Machine Gear Oil, H-1.....	85

T	
Tablet Dedusters	28-30
Tablet Hardness Testers	
Portable Handheld Hardness Tester	34
Stainless Steel Handheld Hardness Tester.....	34
Tablet Hardness & Thickness Tester	35
Tablet Storage Box, Clear Membrane Plastic.....	97
Tablet Thickness Gauge	
Digital Quick Mini Gauge	63
Handheld Digital	63
Tableting Specification Manual	70

Tabletop Ultrasonic Cleaning Units	41
Telescoping Inspection Mirror	20
T-Handle Torque Wrenches	13
Thermometer	
Digital Immersion.....	41
Infrared Laser	35
Tight Punch Removal Tool.....	19
Tip Mounted Dust Cups	22-23
Tooling Storage Box Transport Cart.....	89
Tooling Storage Box Trays.....	42, 88
Tooling Storage Boxes	88
Tooling Storage Protectant	84
Tooling Tray Replacement Tips.....	41
Tooling Tray, Stainless Steel	41
Tool Management II System (TM-II).....	54
Tool Management II Kits.....	55
Torque Analyzer (VeriTorq® Digital)	14
Torque Screwdrivers	14
Torque Wrenches.....	13
Turret Guide Cleaning Brushes	47
Turret Inspection Kits, Certified.....	67
Turret Keyway Inspection Gauges	68

U	
Ultra-Stiff Nylon Bristle Brushes	47
Ultrasonic Cleaning	
3-Piece System	40
Cleaning Solutions	43
Tabletop Units.....	41
Unsewn Buffing Wheels.....	75
Utility Carts.....	96

V	
V-Blocks	
V-Block with Head and Key Cutout	65
V-Block with Head and Key Cutout and Pin Driving Opening	65
V-Block Kit, Multi-Tip/Rotating Head.....	65
V-Block Plate with Nest	56, 65
Vacuums	
3-Phase System.....	31
Dry/Wet Dust Extracting.....	32
Industrial.....	31
Validation Gauge	
3-Step Validation Height Standard Gauges.....	61
Height Standard Gauge	61
Vise.....	65

W	
Walnut Polishing Media.....	73
Wash Basin, Acetal.....	45
White Rouge Bar.....	80
WiGauge Digital Tester	57
Wipes	
Lint-Free	48
¼ Fold Work Wipes.....	79
Wire Shelving.....	94-95
Wire Tooling Baskets, Stainless Steel	42
Work Wipes Dispenser	79

NATOLI REPRESENTATIVES

Natoli Engineering has representatives in over 80 countries around the world. Plan to partner with us!

ALGERIA

Jordan Technology Access
Ouari Nassima
M: +213-54-0455413
ouarinassima@gmail.com

ARGENTINA

ARG Pack
Mario Gadaleta
P: + 54-02229-406067
M: + 54-9-11-4187-6913
mario@argpack.com.ar

AUSTRALIA

Niche Engineering and Mechanical Services Pty Ltd
Paul Floyd
P: +61-3.9708-2226
F: +61-3.9708-2223
sales@nicheeng.com.au

AUSTRIA

Natoli Engineering Company, Inc.
Yasar Shaikh
P: +1-636-929-8900
F: +1-636-926-8910
yshaikh@natoli.com

BANGLADESH

FC Exim (BD) Ltd.
Ridwanur Choudhury
P: +88-02-9611817
F: +88-02-9611816
fcchem@gmail.com

BELGIUM

ACM
Stephane Delarue
P: +33-34-462-1111
F: +33-34-457-2208
stephane.delarue@acm-outil.com

BOLIVIA

Natoli Engineering Company, Inc.
Yasar Shaikh
P: +1-636-929-8900
F: +1-636-926-8910
yshaikh@natoli.com

BOSNIA AND HERZEGOVINA

Republika Srpska (RS)
Ferry Trade & Consulting d.o.o.
Helena Budak
P: +381-63.107-9666
F: +381-25.5745-315
helena.budak@ferrygrp.com

BOSNIA AND HERZEGOVINA

Ferry d.o.o.
Goran Maretic
P: +385-1-381-7166
F: +385-1-381-7188
goran.maretic@ferrygrp.com

BRAZIL

Bonampak, LTD.
Jorge Bilynskyj
P: +55-11-5016-4455
F: +55-11-5016-4455
jbilynskyj@bonampak.com.br

BULGARIA

Natoli Engineering Company, Inc.
Dave Holleran
P: +1-636-926-8900
F: +1-636-926-8910
daveh@natoli.com

CANADA

Natoli Canada
Fazal Mohideen
P: +1-416-271-6220
F: +1-905-837-7824
fmohideen@natoli.com

CHILE

Alcaman International
Axel Goyeneche
P: +56-9-5179-7666
alcaman@alcaman.cl

CHINA

Carinate International Corp.
Victor Chou
P: +86-21-6280-6591
F: +86-21-6280-6584
sales@carinate-china.com

Beijing C&C Cambcavi Co., Ltd.

William Hou
P: + 86-137-9318-0002
F: + 86-10-8879-5831
cambcavi@gmail.com

COLOMBIA

Bioquim
Thomas Schonlau
P: +57-1-370-1300
F: +57-1-566-4585
ts@tso4.com

COSTA RICA

Bioquim
Thomas Schonlau
P: +57-1-370-1300
F: +57-1-566-4585
ts@tso4.com

CROATIA

Ferry d.o.o.
Goran Maretic
P: +385-1-381-7166
F: +385-1-381-7188
goran.maretic@ferrygrp.com

CYPRUS

Naphal Co.
Alexandros Nafpaktitis
P: +30-210-8136915
anafpaktitis@naphal.gr

CZECH REPUBLIC

Natoli Engineering Company, Inc.
Dave Holleran
P: +1-636-926-8900
F: +1-636-926-8910
daveh@natoli.com

DENMARK

Natoli Scandinavia
Jens Kristiansen
P: +45-5819-0941
jens@natoli.dk

DOMINICAN REPUBLIC

DM International Trading
David Brito
P: +1-809-548-7447
F: +1-809-227-4313
davidbrito@codetel.net.do

ECUADOR

Ecuatablet
Francisco Campoverde
P: +593-2-2862163
M: +593-098-481-4801
info@ecuatablet.com

EGYPT

ElMehy Engineering Company
Karim ElMehy
P: +202-2-2632775
F: +202-2-2600191
karim_elmehy@mehy.com.eg

EL SALVADOR

Materiales De Empaque S.A. DE C.V.
Martina Anton
P: +503-2557-3052
F: +503-2557-3051
martina@recasa.net

N.R.K. S.A. de C.V.

Carlos Norvik
P: +503-2263-4467
F: +503-2263-4315
norvik@nrksa.com

ESTONIA

Natoli Scandinavia
Jens Kristiansen
P: +45-5819-0941
jens@natoli.dk

FIJI

Natoli Engineering Company, Inc.
Yasar Shaikh
P: +1-636-929-8900
F: +1-636-926-8910
yshaikh@natoli.com

FINLAND

Natoli Scandinavia
Jens Kristiansen
P: +45-5819-0941
jens@natoli.dk

FRANCE

ACM
Stephane Delarue
P: +33-34-462-1111
F: +33-34-457-2208
stephane.delarue@acm-outil.com

GERMANY

BM Bomaq Pharmatechnik GMBH
Sebastian Boos
P: +49-421-3308-703
F: +49-421-3308-704
sboos@bomaq.de

GREECE

Naphal Co.
Alexandros Nafpaktitis
P: +30-210-8136915
anafpaktitis@naphal.gr

GUATEMALA

N.R.K. S.A.
Karla Simons
P: +502-2369-5578
F: +502-2369-7613
karla@nrksa.com

GUATEMALA

Represent De Centroamerica, S.A.
Michael Bostelmann
P: +502-2381-3030
F: +502-2360-5854
main@recasa.net

HONDURAS

N.R.K. S.A. de C.V.
Carlos Norvik
P: +503-2263-4467
F: +503-2263-4315
norvik@nrksa.com

HUNGARY

Ferry Contact Kft.
Attila Jordan
P: +36-1-348-6000
F: +36-1-348-6001
jordan@ferry.co.hu

ICELAND

Natoli UK Ltd
Craig Russell
P: +44-0-1623-440794
C: +44-0-7809-212543
craig@natoli-europe.co.uk

INDIA

Natoli Engineering Company, Inc.
Shekhar /Jigna
C: +91-9819813270
C: +91-9967923273
jpatel@natoli.com

IRELAND

Natoli UK Ltd
Stuart Bell
P: +44-0-1623-440794
M: +44-0-7570-979595
stuart@natoli-europe.co.uk

ISRAEL

BSC Distributors LTD.
Gadi Ben-Meir
P: +972-9-956-9725
F: +972-9-956-9724
benmeir@bsce.co.il

ITALY

MM Service
Michela Militello
P: +39-370-3155220
mmservice@mmilitello.com

JAPAN

Kikusui Seisakusho LTD.
Hitoshi Kusunoki
P: +81-75-841-6326
F: +81-75-803-2077
kusunoki@kikusui.com

JORDAN

Jordan Technology Access
Mahmoud Ayed
P: +962-7-95-01-9877
F: +962-6-53-42-8043
mayed@joaccess.com

KENYA

Natoli Engineering Company, Inc.
Dave Holleran
P: +1-636-926-8900
F: +1-636-926-8910
daveh@natoli.com

KOSOVO

Ferry Trade & Consulting d.o.o.
Helena Budak
P: +381-63-107-9666
F: +381-25-5745-315
helena.budak@ferrygrp.com

LATVIA

Natoli Scandinavia
Jens Kristiansen
P: +45-5819-0941
jens@natoli.dk

LITHUANIA

Natoli Scandinavia
Jens Kristiansen
P: +45-5819-0941
jens@natoli.dk

MACEDONIA

Ferry Trade & Consulting d.o.o.
Helena Budak
P: +381-63-107-9666
F: +381-25-5745-315
helena.budak@ferrygrp.com

MALAYSIA

REPASSA Ltd.
Jason Chong
P: +6-03-7806-1070
F: +6-03-7806-1077
jason@repassa.com

MALTA

Natoli UK Ltd
Craig Russell
P: +44-0-1623-440794
M: +44-0-7809-212543
craig@natoli-europe.co.uk

MEXICO

Sistemas Industriales de Mexico, S.A. de C.V.
Ruben Torres
P: +52-55-5286-1067
F: +552-55-5211-3443
rtorres@simex-sa.com.mx

MONTENEGRO

Ferry Trade & Consulting d.o.o.
Helena Budak
P: +381-63-107-9666
F: +381-25-5745-315
helena.budak@ferrygrp.com

NETHERLANDS

Natoli UK Ltd
Stuart Bell
P: +44-0-1623-440794
M: +44-0-7570-979595
stuart@natoli-europe.co.uk

NEW ZEALAND

Natoli Engineering Company, Inc.
Yasar Shaikh
P: +1-636-929-8900
F: +1-636-926-8910
yshaikh@natoli.com

NIGERIA

Natoli Solid Dose Supply Company
P. F. Aderemi
P: +234-0-806-882-4594
F: +234-0-705-354-9573
dupebabatunwase@yahoo.com

NORWAY

Natoli Scandinavia
Jens Kristiansen
P: +45-5819-0941
jens@natoli.dk

PAKISTAN

Business Links Int'l (PVT) LTD.
Muhammad Ali Siddiqui
P: +92-21-241-7280
P: +92-21-241-9227
F: +92-21-241-9476
blikar@businesslinks-pk.com

PARAGUAY

Natoli Engineering Company, Inc.
Yasar Shaikh
P: +1-636-929-8900
F: +1-636-926-8910
yshaikh@natoli.com

PERU

Powertron
Roberto Ordonez V.
M: + 51-993-019-185
P: + 511-436-7066
ro@maqfa.net

POLAND

Natoli Polska
Grzegorz Grzybowski
P: +48-693-975-705
F: +48-61-62-47-765
grzegorz.grzybowski@natolipolska.pl

PORTUGAL

JM Consulting
Júlio Martins
P: +351-219417969
M: +351-917250076
martins48j@gmail.com

PUERTO RICO

Pharm ND
Noel Davila
P: +1-787-725-0834
F: +1-787-701-1207
noeldavila@natoli.com

ROMANIA

Ferry P&C srl
Adriana Petruta
P: +40-730-512-562
F: +40-372-876-170
adriana.petruta@ferrygrp.com

Natoli Scandinavia

Jens Kristiansen
P: +45-5819-0941
jens@natoli.dk

RUSSIA

Pharma Contract
Aleksander Grinchenko
P: +7-495-2520098
M: +7-985-770-50-65
a.grinchenko@phct.ru

SAUDI ARABIA

Jordan Technology Access
Mahmoud Ayed
P: +962-79-593-5010
F: +962-65-342-804
mayed@joaccess.com

SERBIA

Ferry Trade & Consulting d.o.o.
Helena Budak
P: +381-63-107-9666
F: +381-25-5745-315
helena.budak@ferrygrp.com

SINGAPORE

REPASSA Ltd.
Patrick Toh
P: +65-6368-7919
F: +65-6368-6566
patrick@repassa.com

SLOVAKIA

Ferry Contact Kft.
Attila Jordan
P: +36-1-348-6000
F: +36-1-348-6001
jordan@ferry.co.hu

SLOVENIA

Ferry d.o.o.
Goran Maretic
P: +385-1-381-7007
F: +385-1-381-7188
goran.maretic@ferrygrp.com

SOUTH AFRICA

Formpak (Pty) Ltd.
Thomas Haase
P: +27-11-828-8870/1/2/3
F: +27-11-828-8880/4
thomas@formpak.com

SOUTH KOREA

Natoli Engineering Company, Inc.
Yasar Shaikh
P: +1-636-929-8900
F: +1-636-926-8910
yshaikh@natoli.com

SPAIN

Maqfa
Jan-Michael Schonlau
P: +34-93-212-4034
F: +34-93-212-4594
jms@maqfa.com

SWEDEN

Natoli Scandinavia
Jens Kristiansen
P: +45-5819-0941
jens@natoli.dk

SWITZERLAND

Natoli Engineering Company, Inc.
Yasar Shaikh
P: +1-636-929-8900
F: +1-636-926-8910
yshaikh@natoli.com

TAIWAN

Carninate International Corporation
Skipper Jou
P: +886-2-2708-8287
F: +886-2-2703-9371
carinate@ms4.hinet.net

THAILAND

REPASSA, Ltd.
Romuald Rostren
P: +66-2101-3671
F: +66-2101-3671
romu@repassa.com

TUNISIA

Activitool S.A.R.L
Ayman Sellami
P: +216-99-660-436
F: +216-71-941-941
contact@activitool.tn

TURKEY

BSC Distributors LTD.
Esin Habif
P: +972-9-956-9725
M: +972-58-412-4777
esin@bsce.co.il

UNITED KINGDOM

Natoli UK Ltd
Craig Russell
P: +44-0-1623-440794
M: +44-0-7809-212543
craig@natoli-europe.co.uk

UNITED KINGDOM

Natoli UK Ltd
Stuart Bell
P: +44-0-1623-440794
M: +44-0-7570-979595
stuart@natoli-europe.co.uk

 **UNITED STATES**

Natoli Engineering Company, Inc.
Dale Natoli
P: +1-636-926-8900
F: +1-636-926-8910
sales@natoli.com

URUGUAY

Natoli Engineering Company, Inc.
Yasar Shaikh
P: +1-636-929-8900
F: +1-636-926-8910
yshaikh@natoli.com

VENEZUELA

Bioquim
Thomas Schonlau
P: +57-1-370-1300
F: +57-1-566-4585
ts@tso4.com

VIETNAM

Tien Tuan Pharmaceutical Machinery Ltd.
Nguyen Ngoc Ha Doan
P: +84-8-38152951 ext.106
F: +84-8-38152953
nnhdoan@tientuan.com.vn

 **HEADQUARTERS**

THE TABLET COMPRESSION CYCLE

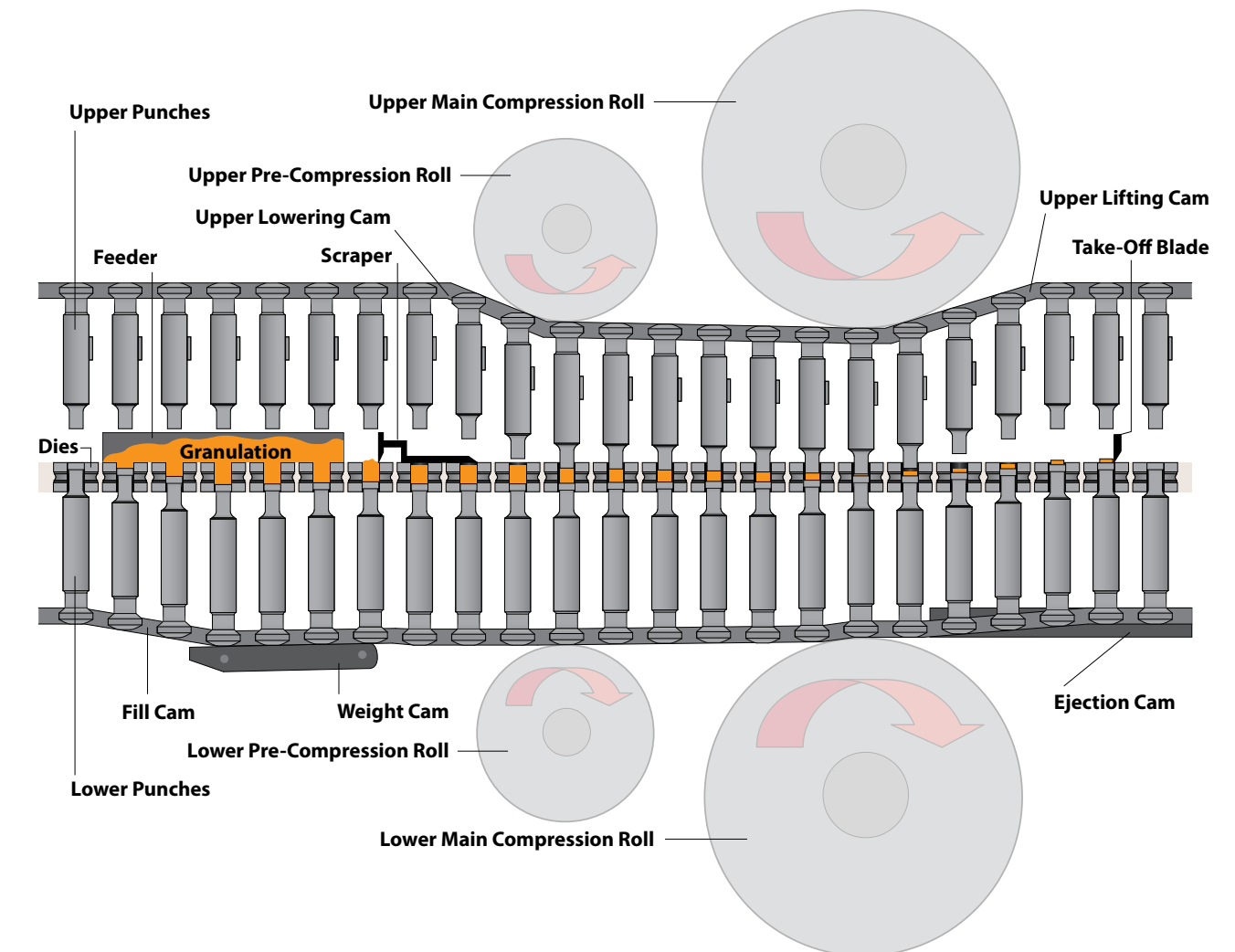

TOOLING TERMINOLOGY

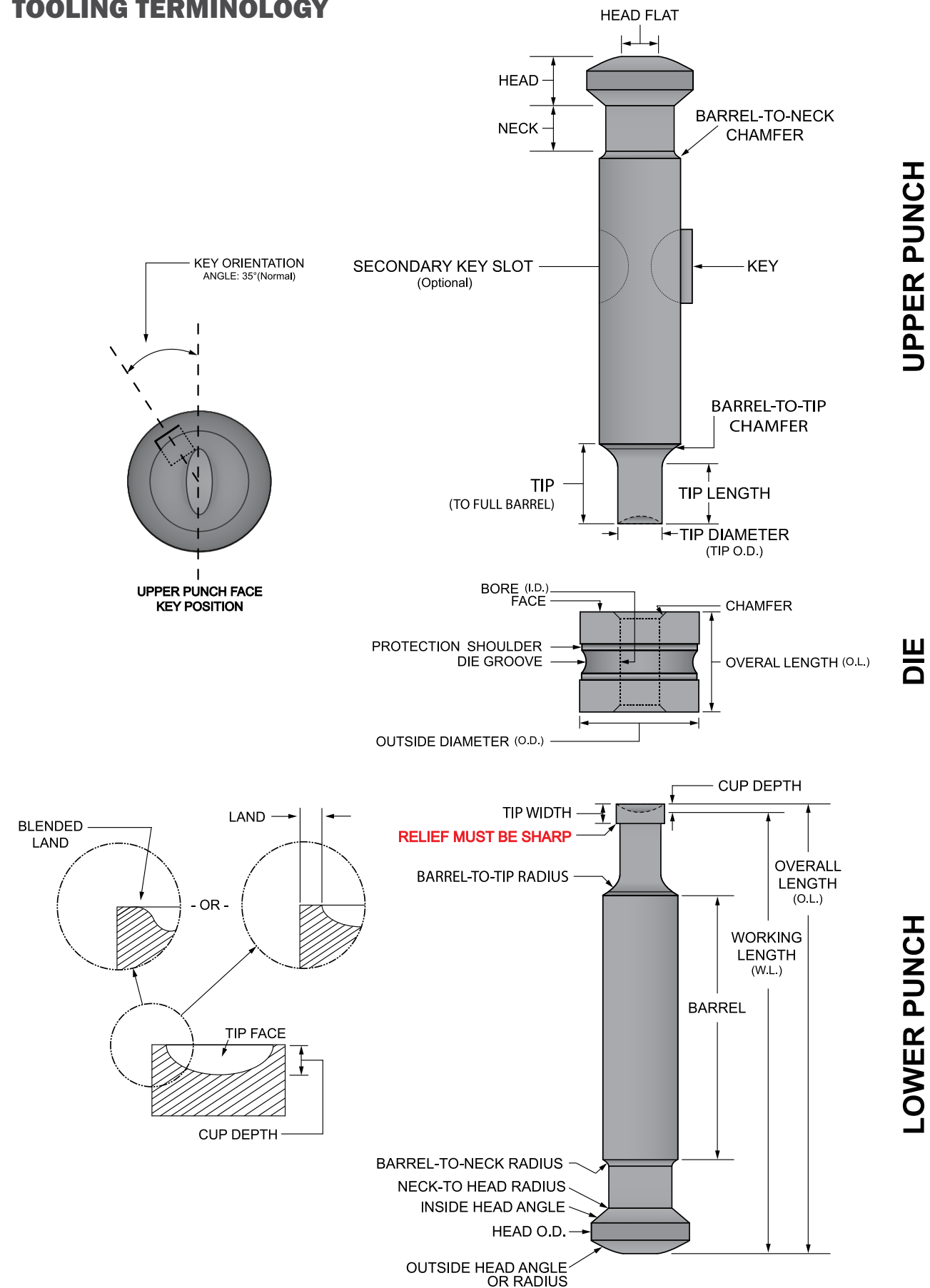

UPPER PUNCH

DIE

LOWER PUNCH

ABBREVIATION	EXPLANATION
°C/°F	Degrees Celsius/Fahrenheit
API	Active Pharmaceutical Ingredient
AFS	Automatic Feed System
cCSAus	Canada & United States Approved
CCW	Counterclockwise
CE	Certified for European Standards
CFM	Cubic Feet per Minute
CFR	Code of Federal Regulations
cGMP	Current Good Manufacturing Practices
CSA	Canadian Standards Association
CW	Clockwise
dia	Diameter
DSP	Digital Signal Processing
EP	European Pharmacopeia
FDA	Food and Drug Administration
ft	Foot
g	Gram
H-1	Food-Grade Lubricant
Hz	Hertz
ID	Inside Diameter
IEC	International Electrotechnical Commission
in	Inch
ISO	International Organization for Standardization
kg	Kilogram
Kp	Kilopond
kW	Kilowatt
L	Liter
lb	Pound
LCD	Liquid Crystal Display
LED	Light-Emitting Diode
LIF	Light Induced Fluorescence
LVS	Laser Vision System
m	Meter
MIL	Military
ml	Milliliter
mm	Millimeter
MPGM	Multi-Purpose Grease with Moly
ms	Millisecond
N	Newton
NIST	National Institute of Standards and Technology
NLGI	National Lubricating Grease Institute
OD	Outside Diameter
OL	Overall Length
OPC	OLE for Process Control (Data Communication)
oz	Ounce
PCB	Printed Circuit Board

ABBREVIATION	EXPLANATION
PMT	Photomultiplier Tube
POE	Power Over Ethernet
ppm	Parts per Million
PSI	Pounds per Square Inch
PTFE	Polytetrafluoroethylene (Teflon)
QC	Quality Control
rpm	Revolutions Per Minute
SAE	Society of Automotive Engineers
SC	Strong Cobb
SDS	Safety Data Sheets
SPC	Standard Process Control
TLR	Timken Load Rating (Indicates wear-protection)
TPM	Tablets Per Minute
TPH	Tablets Per Hour
µm	Micrometer
UHMW	Ultra High Molecular Weight
UL	Underwriters Laboratories
USB	Universal Serial Bus
USDA	United States Department of Agriculture
USP	United States Pharmacopeia
V	Volt
VAC	Volts Alternating Current
VDC	Volts Direct Current
W	Watt
WEP	Wires Equivalent Privacy
WLAN	Wireless Local Area Network

CONVERSIONS

Dimensions

- 1 micrometer = 0.001 millimeters
- 1 inch = 25.4 millimeters
- 1 foot = 12 inches
- 1 foot = 0.3048 meters

Liquid Measurements

- 1 gal = 3.785 liters
- 1 gram = 0.0352739619 ounce
- 1 ounce = 0.125 cup
- 1 ounce = 29.5735296 milliliter
- 1 ounce = 0.0295735296 liter
- 1 milliliter = 0.0338140227 ounce
- 1 milliliter = 0.00422675284 cup
- 1 milliliter = 0.001 liter
- 5 gal = 18.927 liters

Temperature Conversion Formulas

°C x 9/5 + 32 = °F
 (°F - 32) x 5/9 = °C

TOOLING & TABLET TERMINOLOGY**ANNEAL**

A heat-treating process used on fragile punch tips to decrease the hardness of the punch cups, reducing punch tip fracturing

BAKELITE TIP RELIEF

An undercut groove between the lower punch tip straight and the relief; it ensures a sharp corner to assist in scraping product adhering to the die wall; normally a purchased option for lower punches

BARREL OR SHANK

The vertical bearing surface of a punch that makes contact with the punch guides in the machine turret for vertical guidance

BARREL CHAMFER

Chamfers at the ends of the punch barrel; eliminates outside corners

BARREL FLUTES

Vertical slots machined into the punch barrel to reduce the bearing surface and assist in removing product in the punch guides; a purchased option for upper and lower punches

BARREL-TO-STEM RADIUS

The radius that blends the punch barrel to the stem

CAPPING

A tablet defect in which air trapped during compression creates a layer of granulation with air between the granules, which in turn weakens the structure and allows a capping fracture (the tablet top and/or bottom curvature breaks off at or above the band)

CHIPPING

A defect in the tablet in which a piece has broken off the edge

CONCENTRICITY

The measurement from a common center point

DIE

A component used in conjunction with the upper and lower punches; it accepts the product for compaction and is responsible for the tablet's perimeter size and configuration

DIE BORE

The cavity of a die that accepts the product for compaction and determines the tablets size and shape configuration

DIE CHAMFER

The angled area between the top of the die and the die bore; it assists in guiding the upper punch into the die bore

DIE GROOVE

The radial groove around the die OD that accepts the die lock to secure the die in position in the die table

DIE HEIGHT OR OVERALL LENGTH

The entire height or overall length of a die

DIE LOCK

The mechanism used to lock a die in position after it is installed in the die table

DIE OUTSIDE DIAMETER

The largest diameter of a die, commonly referred to as the die OD

DIE TAPER

A gradual increase in dimension, starting from a given depth in the die bore and increasing to the die chamfer; used normally to release air from the die cavity during the compression cycle

FLASHING

A slight imperfection in a tablet in which the material has been compressed above the land in the clearance between the punch tip and the die bore, causing a raised edge

HEAD

The largest diameter of a common punch; it contacts the machine's cams and accepts pressure from the pressure rollers

HEAD BACK ANGLE

Sometimes referred to as the inside head angle, located underneath the top head angle or the top head radius; it contacts the machine camming for vertical movement of the punch within the punch guides

HEAD FLAT

The flat portion of the head, which makes contact with the pressure rollers and determines the maximum dwell time for compression

J-HOOK

A defect of the punch tip caused by wear in which the edge curls inward toward the punch face

KEY

A projection, normally of mild steel, that protrudes above the surface of the punch barrel; it maintains alignment of the upper punch for reentry into the die; mandatory on upper punches with multiple tips and all tablet shapes other than round; commonly used with embossed round tablet shapes when rotation of punch causes a condition known as a double impression

KEY POSITION

The radial and height position of a key on the punch barrel; not found in all presses

LAND

The area between the edge of the punch cup and the outside diameter of the punch tip; this adds strength to the tip to reduce punch tip fracturing

NECK

Located below the head; it provides clearance as the punch cycles through the machine cams

PUNCH OVERALL LENGTH

The total length of a punch, other than flat-face tablet configurations, that is normally a reference dimension that consists of a combination of the working length and the cup depth dimensions

STEM

The area from the barrel to the edge of the punch tip

STICKING

A tablet defect in which material adheres to the smooth surface of the punch tip face

TAPER

A gradual increase in the size of the die bore that extends from the point of compaction to the chamfer of the bore

TIP FACE OR CUP

The portion of the punch tip that determines the contour of the tablet face; it includes the tablet embossing

TIP LENGTH

The straight portion of the punch stem

TIP RELIEF

The portion of the punch stem that is undercut or made smaller than the punch tip straight; most common for lower punches to aid in reducing friction from the punch tip and die wall as the punch travels through the compression cycle; the area where the punch tip and relief meet must be sharp to scrape product from the die wall as the lower punch travels down for the fill cycle

TIP STRAIGHT

The section of the tip that extends from the tip relief to the end of the punch tip; it maintains the punch tip size tolerance

TOOLING SET

A complete set of punches and dies that accommodates all stations in a tablet press

TOOLING STATION

The upper punch, lower punch and die, which accommodate one station in a tablet press

TOP HEAD ANGLE

Angle from the outside head diameter to the top head radius; it allows for sufficient head thickness and smoother camming

TOP HEAD RADIUS

The radius on the top of the head that blends the top head angle to the head flat. Some head configurations may consist of only the head radius without the head angle. This radius makes the initial contact with the pressure roll and allows a smoother transition into the compression cycle

WORKING LENGTH

The dimension from the head flat to the lowest measurable point of the tip face, responsible for the consistency of the tablet overall thickness

The **Global Leader** in Tablet Compression Tooling, Services, and Support

TABLET COMPRESSION TOOLING

TABLET PRESS REPLACEMENT PARTS

TURRET FABRICATION

TABLET PRESS REFURBISHING

TOOL MANAGEMENT (TM II)

TABLET DESIGN SOFTWARE

FULL LINE OF LUBRICANTS

SERVICE CENTERS

TECHNICAL TRAINING

TROUBLESHOOTING



NATOLI ENGINEERING: Dedicated to Supporting Our Industry

Natoli Engineering Company is the world-renowned leader in tablet compression tooling. **But we are far more.** Founded on the uncompromising principle to manufacture and deliver the highest quality products at a fair price with exceptional customer service, Natoli continues to build on 40 years of innovation and industry leadership.

NATOLI ENGINEERING PROVIDES UNPARALLELED SUPPORT IN:



Tool Design



Tablet Compression Accessories



Technical Training



Tablet Design



Tablet Press Replacement Parts



Regional Service Centers



Tablet Press Refurbishment



Scientific and On-Site Consulting



Encapsulation



NATOLI ENGINEERING COMPANY

28 Research Park Circle, Saint Charles, MO 63304
natoli.com • 636-926-8900 • info@natoli.com